

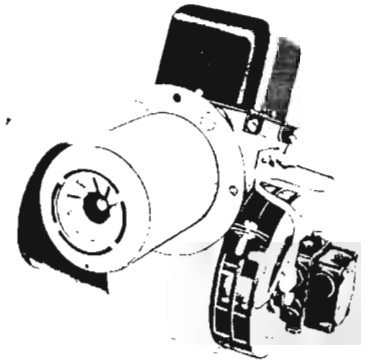

**WAYNE HOME EQUIPMENT
A SCOTT FETZER COMPANY**
801 Glasgow Avenue
Fort Wayne, Indiana 46803

MODEL EASR-S SPECIAL OIL BURNER



Manual—Special

SPECIFICATIONS

FIRING CAPACITIES—MODEL EASR-S

.50 to 1.50 GALLONS PER HOUR
70,000 to 210,000 BTU/HR INPUT

FUELS*

Use No. 1 or No. 2 Heating Oil (ASTM D-396) only.

*Never attempt to use gasoline as a fuel for your burner, as it is more combustible and could result in a serious explosion.

ELECTRICAL

Power Supply115V/60HZ 1 PH
Motor3450 RPM N.E.M.A. Flange, Manual Reset Overload Protection
Ignition10,000 V/23MA Secondary, Continuous Duty-Shielded, Interrupted
Duty-Shielded Transformer, or Solid-State Ignition System.

FUEL UNIT

Sundstrand, or Webster

DIMENSIONS (Standard)

Height11⁷/₈"
Width13⁷/₈"
Depth6⁷/₈"

MOUNTING

Adjustable flange or Base mount.

TO THE HOMEOWNER

Since 1928, Wayne has supplied the Homeowner of the world with oil burners. You are obtaining quality and design unsurpassed with the engineering and product development. It will provide you with many years of efficient, trouble free operation, if properly installed and serviced. Please read this manual carefully.

Wayne warrants its burners specifically to those who have purchased it for resale, including your dealer. If in any case you have a problem with your burner, or its installation, you should contact your dealer for assistance.



APPROVALS

The burner is U.L. listed, for use with Group I or Group II primary safety controls. State and local approvals are shown on burner rating label. All burners should be installed in accordance with National Fire Protection Association, and in complete accordance with all local codes, and authorities having jurisdiction. Regulations of these authorities take precedent over the general instructions provided in this manual.

GENERAL INFORMATION

HEATING PLANT—Before installing this burner in a conversion installation, try to provide adequate space to service the burner properly when installing for easy maintenance; the heating system should be carefully inspected for defects and cleanliness, if proper performance is to be obtained. An oil burner is only a means of supplying heat to the firebox and from there the heating system must absorb and circulate the heat. The flue passages and heat absorbing surfaces must be clean to assure maximum heat transfer to the furnace or boiler. Soot and fly ash act as insulators, retarding the transfer of heat. All doors, openings, and cracks should be cemented airtight to eliminate air infiltration into the heating plant, causing heating losses. Inspect smoke pipe and chimney for elimination of leaks and obstructions. Be sure of adequate chimney size and height. Install a mechanical draft adjuster, if need be, same size as smoke pipe (see column under draft regulators).

Warning:

If this burner is equipped with a relight type control it shall not be used on appliances having brick, ceramic, or castable refractory liner for combustion chamber. Hazard may occur on flame failure because the flame detector may see the hot refractory liner and not respond to flame outage, permitting prolonged delivery of oil before ignition is returned for an attempt to relight the burner.

COMBUSTION CHAMBER

The purpose of a combustion chamber is to maintain a high flame temperature, by reflecting the heat back into the flame. A high temperature assures greater combustion efficiency and lower stack losses. An insulating refractory or a Fiber Fax type chamber can be used with this burner. It is important to select and install, if necessary, the correct size chamber on a conversion job (see chart). On the Flamelock conversion burners the atomized oil burns just off the flamelock. On all oil burners the atomized oil must not touch the sides or bottom of chamber, or smoke will result. To eliminate the smoke, excess air will be required, resulting in high stack temperature and lower combustion efficiency. Install burner so the face of air cone of burner is set $\frac{1}{4}$ " behind the inside front wall of the chamber (see diagram). Caution on installing Flamelock burners in stainless steel chamber should be taken, because of the higher temperature levels produced by high performance flame retention burners. The temp. may exceed the temperature ratings of the stainless steel chamber, and can result in chamber burn outs. Where you are replacing a standard burner with a flame retention burner, take one of the following precautions: (1) Use "Wet Pac" Ceramic Liner to line the inside of chamber, (2) Adjust burner (see Final Adjustments Column).

FUEL UNITS AND OIL LINES

Conversion Burners are provided with single stage 1725 or 3450 RPM fuel units with the by-pass plug removed for single pipe installations; this is satisfactory where the fuel supply is on the same level or above burner permitting gravity flow of oil. Never exceed over 3 PSI pressure to the suction side of fuel unit, a pressure over 8 PSI may cause damage to the shaft seal and allow it to leak oil. When it is necessary to lift the oil to the burner, a return line should be run between fuel unit and oil supply. (If lift exceeds 10 feet, a two stage fuel unit must be used with a return line.) When a two line is used the by-pass plug must be installed, this is supplied along with the burner attached to fuel unit along with an information pump data sheet in a plastic bag. When oil lines are installed continuous runs of heavy wall copper tubing are recommended. Be sure that all connections are absolutely airtight. Check all connections and joints. Flared fittings are recommended. Do not use compression fittings. See pump data sheet for sizing, lift and length for tubing recommendations. Use an oil filter of adequate size for all installations, install inside the building between the tank shut-off valve and the burner. For ease of servicing, locate the shut-off valve and filter near the burner.

TANKS AND PIPING

Local codes and regulations must be adhered to regarding tank and burner installation.

WIRING

All wiring must comply with the National Electric Code and local ordinances. Refer to diagram supplied with burner or controls, making sure the burner and controls are wired correctly and that the line switch is properly fused to burner.

AIR SUPPLY FOR COMBUSTION

Do not install in rooms with insufficient air to support combustion. Occasionally it is necessary to install windows or cut holes in a door to these rooms, to obtain sufficient air and to prevent less than atmospheric air pressures in the room. If there is a lack of combustion air in the room, the burner flame will be yellow and formation of soot will occur in the heating unit. In buildings of conventional frame, brick or stone construction without utility rooms, basement

windows, or stair doors, infiltration is normally adequate to provide air for combustion and for operation of the barometric draft control. For installation in an enclosed utility room without an outside wall, a fresh air opening to the outside with a free cross sectional area of 20 square inches per each gallon per hour firing rate is recommended. For each 1,000 feet above sea level, increase the fresh air opening by at least four (4) per cent. The room should be isolated from any area served by exhaust fans. Do not install an exhaust fan in this room.

CHIMNEY

Follow the recommendations of the heating unit manufacturer. It must be properly designed and of adequate size and should be above the surrounding objects, tile-lined, with no obstructions and be in good state of repair. The smoke pipe should set flush with the inside of tile and cemented in place. All cleanout doors should be sealed.

DRAFT REGULATORS

The use of a draft regulator is recommended and should preferably be mounted in the smoke pipe. Use a draft gauge to adjust to proper opening. When the burner air supply and draft is properly adjusted, the combustion chamber draft will be approximately .01" to .02" WC and the stack draft will be .02 to .04 WC. The larger the installation, the greater the draft will be required at the stack to obtain the .01" to .02" WC at the combustion chamber.

NOZZLES

Use the proper size, type and spray pattern that heater manufacturers recommend; in some cases of upgrading or conversion installations, the use of a 80° Hollow or Solid Nozzle are the best to start with.

STARTING PROCEDURE

STARTING BURNER

Be sure main switch is in "off" position and be sure thermostat is substantially above room temperature, the oil tank is filled, all valves are open and controls set for operation. Adjust air supply on burner by loosening lock screw on outer air band, and open partially. Open the inspection door and turn on switch. Prime pump according to the pump manufacturer's recommendations and check pressure. If safety lockout occurs, reset after 1 or 2 minutes. Do not run fuel unit dry for more than 5 minutes. When fire is established make a temporary air adjustment for a clean combustion flame, reduce air supply until flame tips appear slightly smokey, then readjust so flame tips are clean looking. Leave inspection door open until chamber is dry. When normal temperatures are reached, close inspection door and adjust draft regulator, see column under "DRAFT REGULATORS."

FINAL ADJUSTMENTS

At this point a final adjustment should be used by the use of a COMBUSTION TEST KIT. After operating 10 minutes to warm up unit, a smoke tester should be used to take a smoke reading. We are wanting no greater than a #1; (Shell Bacharach scale) less than a #1 smoke is desired, sometimes a new heating unit requires more time than this to burn clean due to the oil film on the new heater unit surfaces. Recheck draft and take a CO₂ reading over the fire and in the stack. If a large differential between CO₂ readings is noted, air leakage is the most common cause (see column under HEATING PLANT). CO₂ readings must all be taken ahead of draft control. The CO₂ measured in the stack should be at least 9% for oil rates 1.00 G.P.H. or below, and be at least 10% for oil rates over 1.00 G.P.H. Unit should be started and stopped several times to assure good operation. Open inspection door, turn off oil valve and check out safety timing of combustion control. Check operation of limit controls and thermostat. Check for oil leaks. Note: All installations should be reinspected after 1 or 2 ks of normal operation.

FINAL CHECKS

Be sure air shutter and draft control adjustments are locked, and the controls on heating unit are adjusted in accordance with the Heater and Control Manufacturer's Instruction Sheets.

MAINTENANCE

OILING MOTOR—By proper oiling twice a year, the motor life will be increased; only a few drops of a non-detergent type oil at both motor holes are needed.

FILTER—The oil filter cartridge should be replaced once each year so the fuel oil will not become contaminated and plug up fuel pump and nozzle of oil burner.

NOZZLE—The nozzle should be changed at least once each year before the start-up of the heating season. Replace with proper nozzle.

COMPONENTS—If for any reason any of the burner parts have to be replaced, always use parts recommended by the manufacturer. Specify part numbers, and description, when ordering. (IN ALL COMMUNICATIONS STATE BURNER MODEL AND SERIAL NUMBERS).

ELECTRODE SETTINGS—This is very important for reliable ignition of the oil; check these once a year in accordance with the instructions provided in this manual.

FAN & BLOWER HOUSING—This must be kept clean, free of dirt and lint; open transformer to check fan blades for above, be sure the electric power is off on burner when the transformer is opened up for this inspection.



**WAYNE HOME EQUIPMENT
A SCOTT FETZER COMPANY**

801 Glasgow Avenue
Fort Wayne, Indiana 46803

LIMITED WARRANTY

Wayne Home Equipment (Wayne) warrants its products and components to be free from defects due to faulty workmanship or defective materials at time of shipment and under normal use and service for twelve (12) months from the date of installation by a qualified installer or eighteen (18) months from the date of manufacture, whichever date occurs first. This LIMITED WARRANTY does not extend or apply to Wayne's products, or any component thereof, which has been misused, neglected, improperly installed or otherwise abused. Equipment which is defective in material or workmanship and which is removed within the specified time period will be repaired or replaced as follows:

- (1) Field units, control, motors & transformers should be returned to an authorized service point or distributor of Wayne for determination of applicability of this LIMITED WARRANTY as to repair or replacement where said service point or distributor is reasonably available in customer's locality.
- (2) Where such local service is not available for components involving said fuel units, controls, motors & transformers, or where other components are involved, such products should be returned, freight prepaid, to Wayne's home office.
- (3) Products determined to be covered under this LIMITED WARRANTY by Wayne shall be either repaired or replaced at Wayne's sole option.
- (4) Wayne is not responsible for any labor cost for removal and replacement of said products and equipment associated therewith.
- (5) Fuel units, controls, motors & transformers, or other components which are so repaired or replaced will carry this LIMITED WARRANTY equal to the unexpired portion of the original product LIMITED WARRANTY.
- (6) If inspection by Wayne does not disclose any defect covered by this LIMITED WARRANTY, the product will be repaired or replaced at the expense of the customer and Wayne's regular charges will apply.

THE FOREGOING STATES THE SOLE AND EXCLUSIVE REMEDY FOR ANY BREACH OF WARRANTY OR FOR ANY OTHER CLAIM BASED ON ANY DEFECT IN, OR NON-PERFORMANCE OF, THE PRODUCTS, WHETHER SOUNDING IN CONTRACT, WARRANTY OR NEGLIGENCE. NO OTHER WARRANTY, WHETHER EXPRESSED OR IMPLIED, INCLUDING ANY WARRANTY OF MERCHANTABILITY OR FITNESS FOR A PARTICULAR PURPOSE, SHALL EXIST IN CONNECTION WITH THE SALE OR USE OF SUCH PRODUCTS AND IN NO EVENT WILL WAYNE BE LIABLE FOR ANY INCIDENTAL OR CONSEQUENTIAL DAMAGES OF ANY NATURE. Wayne neither assumes nor authorizes any person to assume for Wayne any other liability or obligation in connection with the sale of these products.

OIL BURNER CERTIFICATE

The _____ Oil Burner Model No. _____, Serial No. _____, installed at _____
(MAKE)
_____ Bears a label evidencing compliance with commercial Standard
(ADDRESS OF INSTALLATION)
CS75-56, and has been installed in accordance with the instructions in the manufacturer's installation manual and in conformity with local regulations, codes, and ordinances.

The Boiler
Furnace _____ No. _____, and the
(MAKE)
Input of unit consists of _____ G.P.H., or _____ BTUH

CO ₂	Over Fire _____	Flue Gas Temperature at Breeching _____ °F
	At Breeching _____	Ambient Temperature _____ °F
Draft	Over Fire _____	Net Flue Gas Temperature _____ °F
	At Breeching _____	Firing Rate _____ gals/hrs.
	(inches H ₂ O)	Oil Pressure _____ PSIG

All controls and limiting devices have been checked for proper operation _____
Fuel used, Grade No. _____ of Commercial Standard CS12-48.
Field service equipment smoke scale reading _____

The above test results are certified to be true:

(NAME OF COMPANY MAKING INSTALLATION)

Per _____
(SIGNATURE)

ADDRESS)

(TELEPHONE)

For Service call:

Name _____

Address _____

Telephone _____

Date _____

ATTACHING AIR TUBE COMBINATIONS FOR CHASSIS PLAN ONLY

When the Oil Burner Chassis and the Air Tube Combination are packed separately, the Burner must be assembled as follows:

- 1—Slip Retainer Flange (A) over end of Air Tube (B) as shown, with the counter-sunk side of the four mounting holes toward the **Air Cone End** of Air Tube.
- 2—Install this assembly to the Burner Chassis as shown. This can be done by setting the Burner Chassis on its back and placing the assembled Air Tube and Flange down on the Chassis. (IMPORTANT: Make Sure the Oil Drip hole in Air Cone (see Fig. 1) is at the six o'clock position.) Install the 4-Retainer Screws and secure Air Tube and Flange to Chassis.
- 3—Install proper nozzle in Drawer Assy. Loosen the Transformer Retainer Screws and swing open to insert the Drawer Assy. (see Fig. 2). into the air tube to position nozzle. Once installed and adapter fitting is in position in Burner Chassis slot and slide place hole, adjust gun assy., either back or forward to position nozzle from head. For correct positioning (see Fig. 3). Secure the slide plate by tightening screw at side of housing. Secure the drawer assy. with the locknut provided. Attach flared nut of Oil Line Assy., (Copper Oil Line) to the end of this adapter fitting as shown.

Install arrow decal as shown so position of Drawer Assy., is always known. (See Fig. 4)

Recheck for nozzle centering before burner is installed (see Fig. 1). Make sure electrode tips clear retention head.

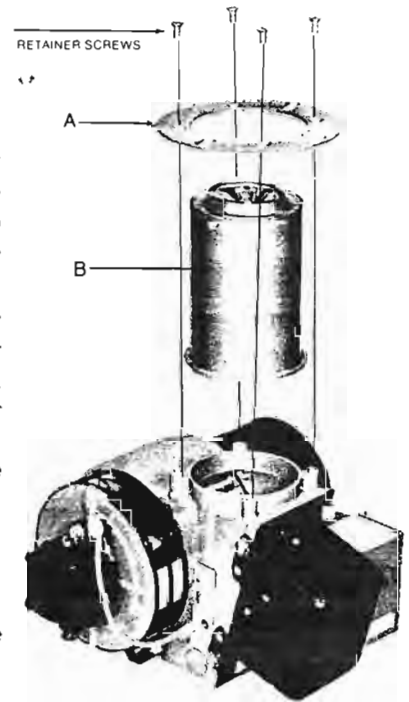

FIG-1

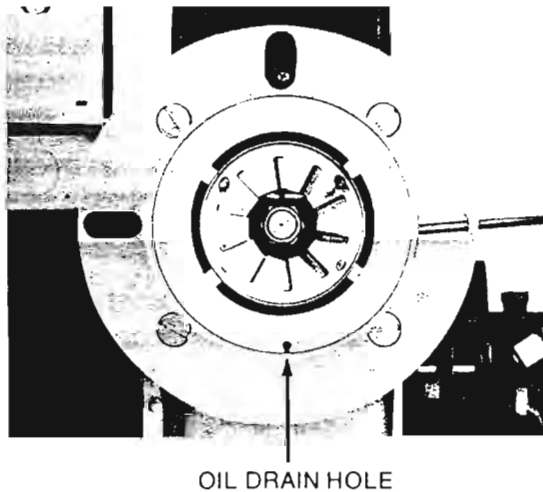

FIG-3

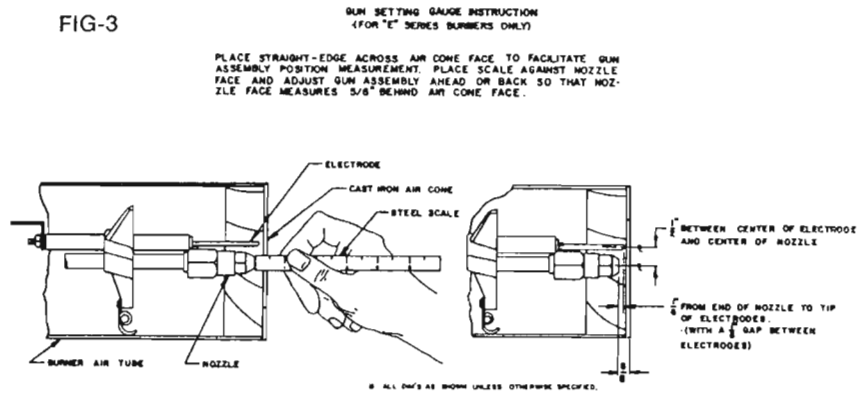

FIG-2

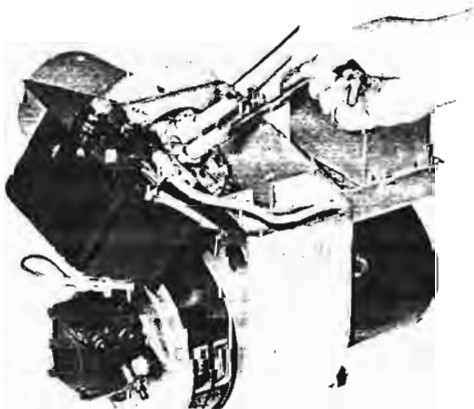
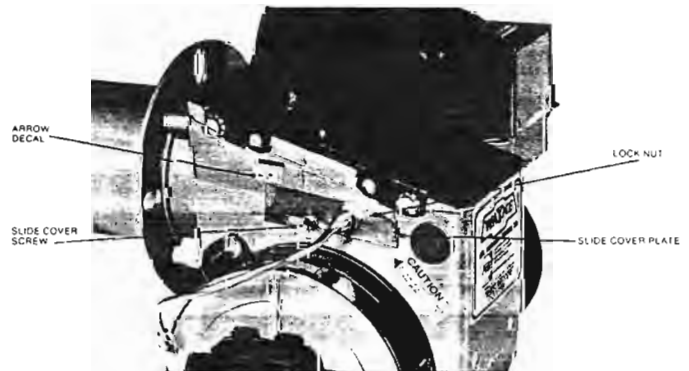
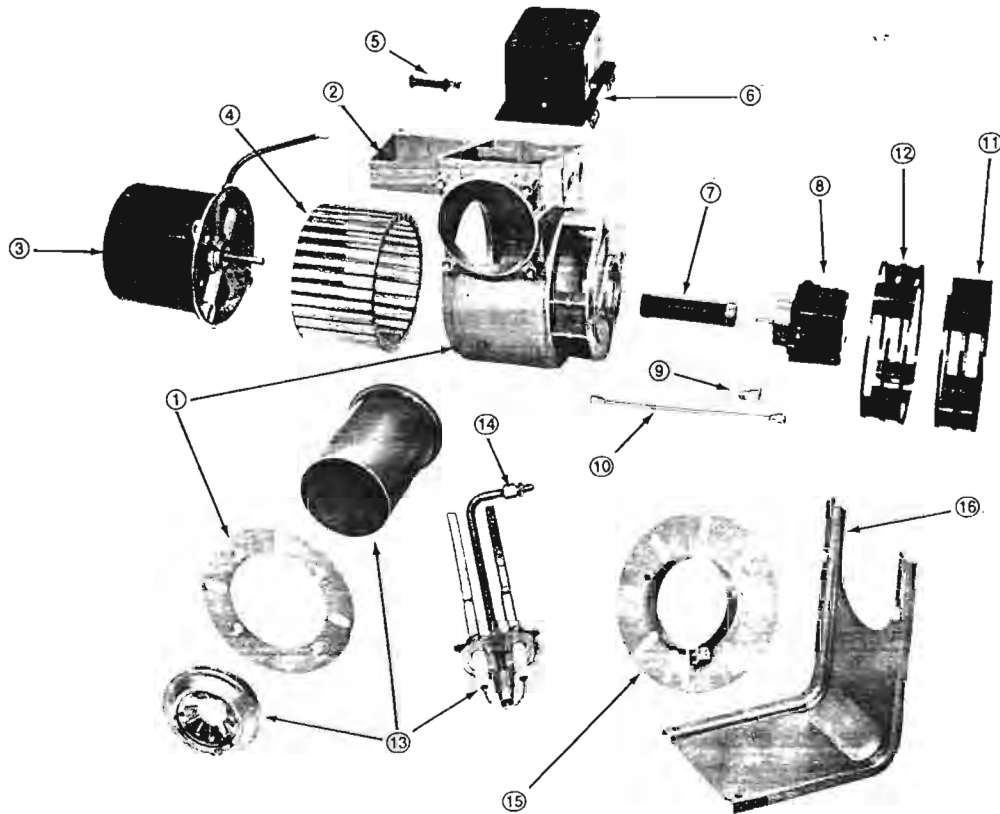

FIG-4



BURNER COMPONENTS MODEL EASR-S



STATE BURNER MODEL, PART DESCRIPTION AND PART NUMBER WHEN ORDERING PARTS

NO.	DESCRIPTION	PART NO.
1	BURNER HOUSING	4725
	MOUNTING FLANGE	21426
2	JUNCTION BOX	21419
3	MOTOR	20547
4	BLOWER WHEEL	21149
5	MOTOR CORD COVER	13121
6	TRANSFORMER	20358
7	COUPLING	13279
8	FUEL UNIT MODEL-A	13512
	FUEL UNIT MODEL-B	13633
9	OUTLET FITTING	13494
10	OIL LINE ASSEMBLY	14452
11	INNER AIR BAND	2669
12	OUTER AIR BAND	2668

No.	DESCRIPTION	PART NO.
13	AIR TUBE & GUN ASSY. COMBINATION	*
14	OIL TUBE LOCK NUT	14296
15	ADJUSTABLE FLANGE	2689
16	PEDESTAL MOUNT	2794

*SPECIFY AIR TUBE & GUN ASSY. COMBINATION PART NUMBER SEE PAGE 8

Suggested Combustion Chamber Dimensions Conversion or Upgrading Chamber Dimensions (In Inches)					
Firing Rate (G.P.H.)	Square		Round	Height	Floor to Nozzle
	Width	Length			
.85	8.5	8.5	9	12	5-6
1.00	9	9	10 ¹ / ₈	12 ¹ / ₂	5-6
1.25	10	10	11 ¹ / ₄	12 ¹ / ₂	5-6
1.35	10 ¹ / ₂	10 ¹ / ₂	11 ³ / ₄	12 ³ / ₄	5-6
1.50	11	11	12 ³ / ₈	13	5-6
1.65	11 ¹ / ₂	11 ¹ / ₂	13	13 ¹ / ₄	5-6
2.00	12 ⁵ / ₈	12 ⁵ / ₈	14 ¹ / ₄	13 ¹ / ₂	6-7
2.50	14 ¹ / ₄	14 ¹ / ₄	16	14	7-8
3.00	15 ¹ / ₂	15 ¹ / ₂	17 ¹ / ₂	15	7-8

AIR TUBE & GUN ASSEMBLY DETAILS MODEL—EASR-S

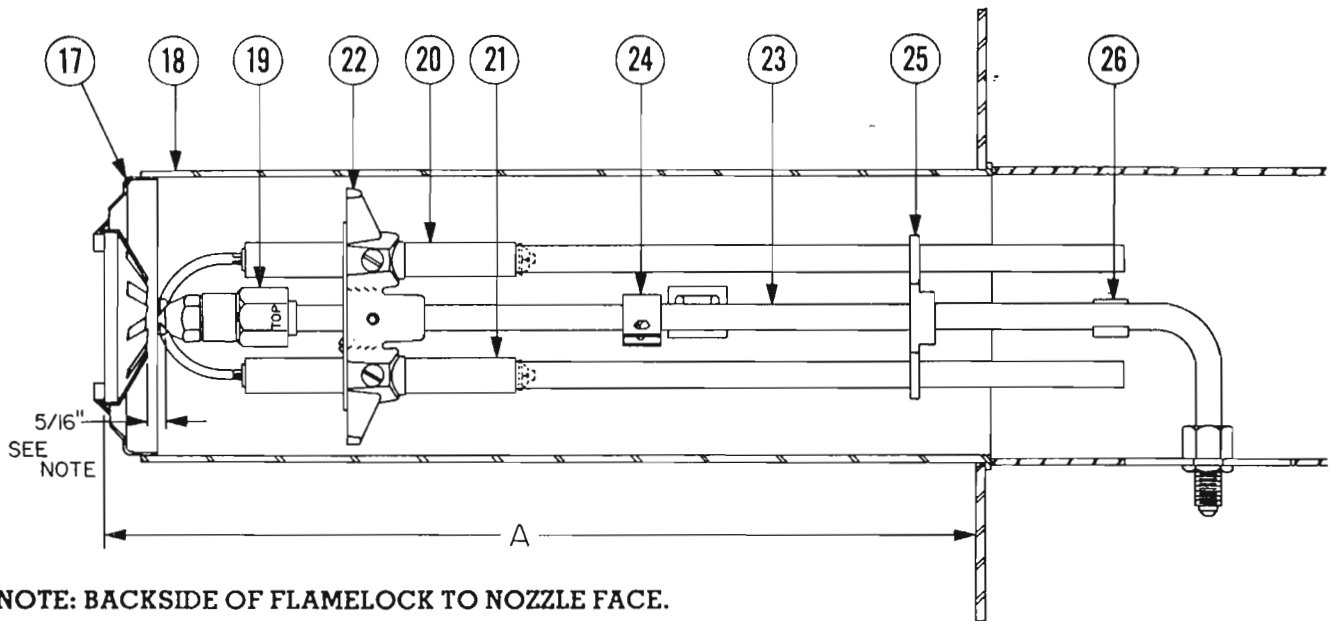

NOTE: BACKSIDE OF FLAMELOCK TO NOZZLE FACE.

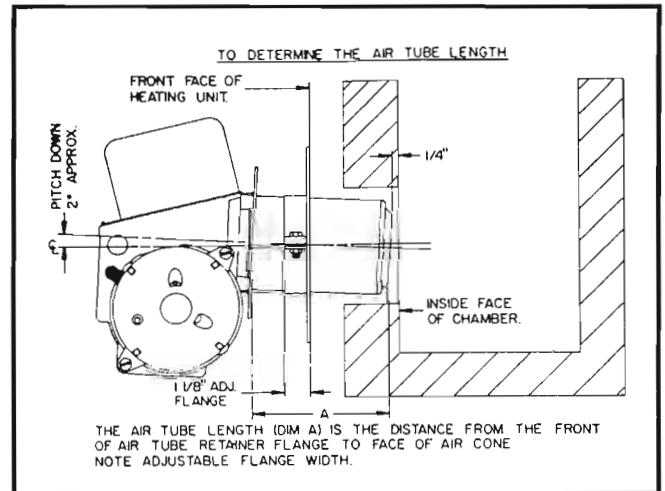
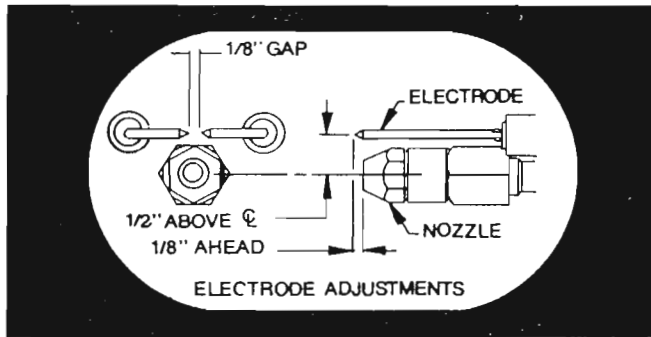

AIR TUBE & GUN ASSY. PARTS			
17	HEAD .50-.75	5A	14302
	.75-1.10	6A	14365
	1.25-1.50	3A	14159
18	AIR TUBE		SEE NOTE
19	NOZZLE ADAPTER		12362
20	RIGHT ELECTRODE ASSY.		SEE NOTE
21	LEFT ELECTRODE ASSY.		SEE NOTE
22	ELECTRODE SUPPORT ASSY.		SEE NOTE
23	OIL PIPE ASSY.		SEE NOTE
24	CAD CELL BRACKET		13078
25	BUSS BAR SUPPORT		100029
26	CAD CELL WIRE CLIP		13083

AIR TUBE LGT DIM.-A-	STANDARD AIR TUBE COMBINATIONS FIRING RANGE G.P.H.		
	.50-.75	.75-1.10	1.25-1.50
6"	30669	30675	30856
9"	30670	30676	30857
12"	30671	30677	30858
15"	30672	30678	30859
18"	30673	30679	30860
20"	30674	30680	30861

NOTE: WHEN ORDERING STATE BURNER MODEL EASR-S PART DESCRIPTION, AIR TUBE COMBINATION, WHAT USABLE AIR TUBE LENGTH, (DIMENSION A), AND FIRING RATE.