



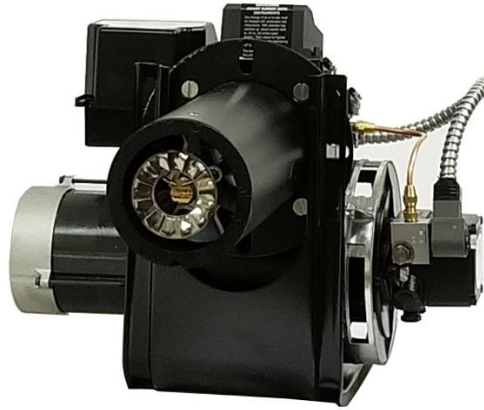
WAYNE COMBUSTION SYSTEMS  
801 GLASGOW AVE.  
FORT WAYNE, IN 46803

PHONE: (260) 425-9200  
(855) WAYNECS  
(800) 443-4625  
FAX: (260) 424-0904

www.waynecombustion.com

# MODEL EH, EHA & EHASR OIL BURNERS

Manual 21530 | Revision 11 | Publication Date: 6/1/2023



UL File Number: MP-98

## SPECIFICATIONS

### Firing Capacities:

#### Model EHA & EHASR

0.75 – 3.00 gal/hr  
105,000 – 420,000 Btu/hr Input

#### Model EH

3.00 – 6.00 gal/hr  
420,000 – 840,000 Btu/hr Input

### Fuel Pumps

Single Stage Standard

### Electrical

Power Supply .....120 Vac 60Hz, 230 Vac 60 Hz 1 Phase; optional 230 Vac 50 Hz 1 Phase

Motor .....3450 rpm, Automatic Reset Overload Protection

Ignition .....14,000 V secondary, Continuous Duty or Interrupted Duty

**Fuels:** Use No.1 or No.2 heating oil (ASTM D-396),  
Kerosene, Diesel (ASTM D975-18), JP8

### Dimensions (Standard):

Height .....12 1/2"  
Width .....15 1/2"  
Depth ..... 8 1/4"  
Center Line of Tube to Floor ..... 8 1/16"

### Mounting:

Rigid Flange, Adjustable Flange, or Pedestal Mount



**READ THIS MANUAL BEFORE USING THIS PRODUCT. FAILURE TO FOLLOW THE INSTRUCTIONS AND SAFETY PRECAUTIONS IN THIS MANUAL CAN RESULT IN SERIOUS INJURY OR DEATH. KEEP THIS MANUAL FOR FUTURE REFERENCE. INSTALLER: LEAVE THIS MANUAL WITH THE END USER.**



**INSTALLATION OF THE BURNER MUST BE DONE BY A QUALIFIED INSTALLER IN ACCORDANCE WITH REGULATIONS OF THE NATIONAL FIRE PROTECTION AGENCY, NFPA NO. 31, AND IN COMPLETE ACCORDANCE WITH ALL LOCAL CODES AND AUTHORITIES HAVING JURISDICTION.**

**A QUALIFIED INSTALLER IS THE PERSON WHO IS RESPONSIBLE FOR THE INSTALLATION AND ADJUSTMENT OF THE EQUIPMENT AND WHO IS LICENSED TO INSTALL OIL-BURNING EQUIPMENT IN ACCORDANCE WITH ALL CODES AND ORDINANCES.**



## Overview of Safety Warning System and Your Responsibilities

The safety of you and others depends upon you thoroughly reading and understanding this manual. If you have questions or do not understand the information presented in this manual, **please call Wayne Combustion Systems or see [www.waynecombustion.com](http://www.waynecombustion.com)**.



This is the safety alert symbol. It is used to alert you to potential personal injury hazards. The meaning of this safety alert symbol is as follows: **Attention! Become alert! Your safety may be at risk. The message that appears next to the warning describes the hazard, which can be either written or pictorially presented. NEVER remove or tamper with the warning labels, safety devices or guards fitted on the unit.**

Wayne Combustion Systems is **NOT** responsible for any bodily injury and/or property damage that may result from operation outside of the stated operating conditions for which this unit was intended.

### Hazard Definitions:



Indicates a hazardous situation, which, if not avoided, will result in **death or serious bodily injury**.












Indicates a hazardous situation, which, if not avoided, could result in **death or serious bodily injury**.



Indicates a hazardous situation, which, if not avoided may result in **minor or moderate bodily injury**.



Indicates a situation that may result in equipment-related damage.

Hazard Level	Pictogram	Type	Hazard Explanation
 <b>WARNING</b>		Fire or Explosion	<p>Failure to follow safety warnings exactly could result in serious injury, death or property damage.</p> <p>Do not store or use gasoline or other flammable vapors and liquids in the vicinity of this or any other appliance.</p> <p>Never attempt to use gasoline as a fuel for this burner, as it is more combustibile and could result in a serious explosion.</p>
 <b>WARNING</b>		Electric Shock or Burn	<p><b>High voltages are present in this equipment. Follow these rules to avoid electric shock:</b></p> <ul style="list-style-type: none"> <li>• Use only a properly grounded circuit. A ground fault interrupter is recommended.</li> <li>• Do not spray water directly on burner.</li> <li>• Turn off power before servicing.</li> <li>• Read the owner's manual before using.</li> </ul>
 <b>WARNING</b>		Overheating	<p><b>Should overheating occur:</b></p> <ul style="list-style-type: none"> <li>• Shut off the manual oil valve to the appliance.</li> <li>• Do not shut off the control switch to the pump or blower.</li> </ul>
 <b>WARNING</b>		Carbon Monoxide Poisoning	<p><b>Carbon monoxide is a colorless, odorless gas that can kill. Follow these rules to control carbon monoxide:</b></p> <ul style="list-style-type: none"> <li>• Do not use this burner if in an unvented, enclosed area. Carbon monoxide may accumulate.</li> <li>• Check flue gases for carbon monoxide. This check requires specialized equipment.</li> <li>• Allow only qualified burner service persons to adjust the burner. Special instruments and training are required.</li> <li>• Read the burner manual before using.</li> </ul> <p><b>CARBON MONOXIDE POISONING:</b> Early signs of carbon monoxide poisoning are similar to the flu with headaches, dizziness, weakness, nausea, vomiting, sleepiness, and confusion. If you suspect carbon monoxide poisoning, get outside to fresh air immediately, and then call 911. Some people are more affected by carbon monoxide than others. These include pregnant women, people with heart or lung disease or anemia, those under the influence of alcohol, and those at high altitudes.</p>
 <b>WARNING</b>		Proposition 65 material	<p>This product can expose you to chemicals, including lead, nickel, carbon monoxide and sulfur dioxide, which are known to the State of California to cause cancer or birth defects or other reproductive harm. For more information, go to <a href="http://www.p65Warnings.ca.gov">www.p65Warnings.ca.gov</a>.</p>
 <b>NOTICE</b>		Special Requirements	<p>When contacting Wayne Combustion Systems for service information, please have the burner specification and model number when calling or writing. Specification number will be located on a 1" X 2" rectangular sticker on the back of the burner and model number is on the big square sticker that has the manufacturer's logo and contact information. This sticker will be above the specification label.</p>

# Contents

GENERAL INFORMATION .....	6
TROUBLESHOOTING.....	7
GENERAL TROUBLESHOOTING GUIDE .....	7
BURNER DOES NOT LIGHT, HONEYWELL CONTROL REMAINS ON STANDBY.....	10
BURNER WILL LIGHT, BUT WILL NOT STAY LIT DURING “CALL FOR HEAT” .....	10
WIRING DIAGRAMS .....	16
SEQUENCE OF OPERATION: BURNERS WITH R7284G AND R8184G CONTROLS .....	17
SEQUENCE OF OPERATION: BURNER WITH R7284P CONTROL.....	18
SEQUENCE OF OPERATION: BURNER WITHOUT CONTROL .....	19
OPERATIONAL CHECK OF BURNER .....	19
START SYSTEM .....	19
CHECK SAFETY FEATURES.....	19
GENERAL INSTALLATION INFORMATION .....	20
COMBUSTION CHAMBER.....	20
FUEL PUMPS .....	20
FUEL LINES .....	20
FUEL TANKS.....	21
ELECTRICAL WIRING OF BURNER.....	21
CHIMNEY INSTALLATION .....	21
DRAFT REGULATORS .....	21
AIR SUPPLY FOR COMBUSTION .....	22
NOZZLE AND AIR CONE SELECTION .....	22
NOZZLE INSTALLATION .....	22
SETTING GUN DEPTH .....	27
STARTING PROCEDURE.....	30
STARTING BURNER.....	30
FINAL ADJUSTMENTS .....	32
SETTING COMBUSTION EFFICIENCY .....	32
FINAL CHECKS.....	33
MAINTENANCE .....	33
REFERENCE INFORMATION.....	34
REFERENCE FIGURES .....	36
OIL PIPE SIZING INFORMATION .....	37
WARRANTY .....	40

# GENERAL INFORMATION



Read this manual carefully and in its entirety prior to performing any maintenance or service on the burner.

## WARRANTY

Wayne Combustion Systems warrants its burner's specifically to organizations that have purchased it for resale, including your dealer. If you have a problem with your burner, or its installation, you should contact your dealer for assistance, for a full description of the warranty see page 40.

## MAINTENANCE

Wayne Combustion Systems recommends yearly inspection/service of your oil heating system by a qualified service agency or individual.

A qualified service agency or individual must be:

- Licensed or certified to install and provide technical service to oil heating systems.
- Experienced with all applicable codes, standards and ordinances.
- Responsible for the correct installation and commission of the equipment.
- Skilled in the adjustment of oil burners using combustion test instruments

## APPROVALS

This burner complies with ANSI/UL Standard 296 and is for use with No. 1 fuel oil or No. 2 fuel oil and is UL listed for use with Group I or Group II primary safety controls. The states of Massachusetts, New York and local approvals are shown on the burner's nameplate label. All burners must be installed in accordance with the National Fire Protection Association, and in complete accordance with all local codes and authorities having jurisdiction. Regulation of these authorities takes precedence over the general instructions provided in this manual.

## MANUAL ORGANIZATION

This manual is organized so that the licensed contractor can troubleshoot the service issue with the burner by working through the **GENERAL TROUBLESHOOTING GUIDE** on page 7. The **GENERAL TROUBLESHOOTING GUIDE** is organized by the performance issue or "problem" requiring attention. Each problem will list potential root causes that may result in the problem listed in order from most likely to least likely, and the solution to correct each root cause that may be affecting burner performance. The solution listed for each root cause will reference supplemental information regarding normal burner/component operation and service instructions depending on the problem and root-cause. If this is a new installation see **GENERAL INSTALLATION INFORMATION** on page 20.

## MODEL DIFFERENCES

The EHASR burner utilizes unique air cones and oil gun assemblies to optimize burner performance in its rated firing range. The air cone is a single piece construction and is fixed to the air tube. The oil gun depth is set in reference to the fixed air cone. The EH and EHA have the flamelock attached to the nozzle adaptor on the oil gun, this allows the burner to have a variable gun depth setting based on the firing rate needed. An EHA burner is different from a EH because the EHA uses an oil pump that is rated up to 3 gal/hr, while the EH model will use a larger pump that is rated up to 7 gal/hr to attain the higher firing rates.

## BURNER COMPONENTS

The EHASR, EHA, and EH model burners are constructed with components of varying design. For example, the ignition device may be an iron core transformer or a solid state igniter. Both devices perform the same function, and they use the same troubleshooting methodology. There are also two distinct types of motors utilized by these burners. The "Permanent Split Capacitor" or PSC motors (silver in color) utilize a thermal protection device that automatically resets when the motor cools down. The "Split-Phase" motors (black jacket) utilize a manual reset thermal protector. Appliance or equipment manufacturers may specify one type of component over another. Please contact Wayne Combustion Systems for assistance with replacement component selection.

# TROUBLESHOOTING



**Before troubleshooting, familiarize yourself with the startup procedures and sequence of operation. Check the burner, ignitor or transformer, oil primary control (if equipped), and cad cell (if equipped) for proper operation and condition.**

## Preliminary Steps

Check the following common causes of issues:

- Wiring connections, fuses, power supply to the burner blower motor, controls, and ignition device.
- Limit control is closed.
- Thermostat (controller) is calling for heat.
- Contacts between ignition device and electrodes.
- Electrode gap is properly set at nozzle.
- Oil piping to burner and tank is properly sized and is in good condition (see Oil Pipe Sizing Information on page 37 ).
- Oil pump pressure.
- Oil nozzle is correctly sized for application.
- Check cad cell location and photo eye cleanliness.

## GENERAL TROUBLESHOOTING GUIDE



The Honeywell R7284 oil primary control's reset button is the "i" button, the R7184, R8184 and Wayne control is the big red button. Pressing the reset button and restarting the burner more than once with the burner not lighting could cause oil buildup in the firing chamber. This will cause smoking and possible detonation that could damage the equipment if the burner does light

PROBLEM	POSSIBLE CAUSE	SOLUTION
<b>BURNER WILL NOT LIGHT</b>	Little or no fuel	Fill tank with fuel.
	Improper fuel or water in fuel	Drain fuel tank and fill with proper fuel.
	Limit switch open	Close limit or thermostat switch, and check limit switch for proper cycling operation.
	Improper electrode spacing, gap to small	Clean and position electrode tips according to Figure 14 or Figure 15 on pages 26-27.
	Plugged fuel filter	Replace as needed.
	Misadjusted burner air bands	Re-adjust air bands for clean burn.
	Little or no fuel pressure from fuel pump	Increase fuel pressure to manufacturer's specifications. See Figure 25 on page 36 for pump features. Check that plastic coupler (see Figure 1 on page 13, item 10) is not slipping on pump shaft, replace as needed and/or replace pump.
PROBLEM	POSSIBLE CAUSE	SOLUTION

<b>BURNER WILL NOT LIGHT</b> (continued)	Air bubble sucked and trapped in pump	Bleed pump (see page 31 for instructions) and check all fuel lines for air leaks, replace lines as needed. See Figure 25 on page 36 for pump features.
	Burner motor thermal protector actuated	If tripped, check voltage, connections, and extensions for cause. Check fuel pump shaft rotation for binding causing motor to overheat.
	Flex-coupling slipping on fuel pump shaft or burner motor shaft	Replace as needed. See Figure 1 on page 13, Item 10.
	Fuel not reaching combustion chamber	Check fuel system for proper flow going through the burner.
	Clogged burner nozzle	Replace. See page 22 for instructions.
	Low voltage at burner wire leads	Check for proper 120/230 Vac going to the burner
	Fuel solenoid malfunction	Replace as needed. See Figure 1 on page 13 for replacement part.
	Faulty burner ignition device	Test ignition device for proper arc between contacts. Replace as needed. See Figure 1 on page 13 for replacement part.
	Disconnected or short in electrical wiring	All wire contacts should be clean and tight. No breaks in wire insulation, replace as needed. See page 21 for wire size recommendations.
	Oil primary control sees light during safety check and remains in standby mode (Applicable only if burner comes with oil primary control).	Press and hold the reset button for 2 seconds on a Honeywell control, (push and hold for 3 seconds if it is an older style Wayne control), observe burner sequence of operations. If burner remains on standby see <b>Burner does not light, Honeywell controls remains on standby</b> , on page 10.
	Oil gun depth spaced too far ahead causing electrodes too short to ground through air cone.	Identify burner model and position oil gun depth according to Figure 16 and Figure 17. See page 27 for instructions.
	Heavy sooting on burner electrodes, and air cone causing a weak arc between the electrodes.	Clean as required. Check ceramic for any chips and cracks that could affect arc between the electrodes, replace as required. See Table 2 on page 15 for replacement parts.
<b>BURNER WILL LIGHT, BUT NOT STAY LIT DURING CALL FOR HEAT</b>	Oil primary control goes into nuisance lockout (Applicable only if burner comes with oil primary control).	Press and hold the reset button for 2 seconds on a Honeywell control, (push and hold for 3 seconds if it is an older style Wayne control), observe burner sequence of operations. If burner locks out again see <b>Burner Will Light, But Will Not Stay Lit During "Call For Heat"</b> , on page 10.
<b>BURNER SMOKES</b>	Improper fuel or water in fuel	Drain tank and replace contaminated fuel.
	Improper air adjustment	Re-adjust air bands on burner assembly for clean burn.
	Low fuel pressure	Increase fuel pressure to manufacturer's specifications. See Figure 25 on page 36 for pump features.
	Air leaks in fuel lines	Check fuel lines for leaks or air bubbles. Tighten or replace as needed.
	Plugged or dirty burner nozzle	Replace burner nozzle. See page 22 for instructions.
	Improper nozzle size installed, nozzle size too big	Contact appliance manufacturer for proper nozzle size, and replace. See page 22 for instructions.
<b>PROBLEM</b>	<b>POSSIBLE CAUSE</b>	<b>SOLUTION</b>



<b>BURNER SMOKES</b> (continued)	Heavy accumulation of soot on heat exchanger and burner assembly	Remove burner assembly from heat exchanger. Clean thoroughly.
	Faulty burner nozzle spray pattern	Replace. See page 22 for instructions.
	Misaligned or damaged electrode	Realign electrodes according to Figure 14 or Figure 15 on pages 26-27, and the oil gun depth according to Figure 16 or Figure 17 on pages 27-28.
	Obstruction in smoke stack	Check for blockage or other foreign objects.
<b>BURNER RUNS CONTINUOUSLY WITHOUT SATISFYING CALL FOR HEAT</b>	Improper fuel or water in fuel	Drain fuel tank and fill with proper fuel.
	Reduced fuel pressure	Check fuel pump pressure. Check that fuel filter isn't partially clogged, replace as necessary. Increase fuel pressure to manufacturer's specifications. See Figure 25 on page 36 for pump features. Replace pump if needed.
	Soot build-up on heat exchanger.	Clean heat exchanger with soot remover.
	Improper burner nozzle installed, nozzle size too small.	Contact appliance manufacturer for proper nozzle size, and replace. See page 22 for instructions.
<b>BURNER RUNS BUT APPLIANCE IS OVERHEATING</b>	Fuel pump pressure too high	Readjust fuel pressure to appliance manufacturer's specs. See Figure 25 on page 36 for pump features.
	Oil primary control keeps energizing burner past "call for heat". (Applicable only if burner comes with oil primary control).	Identify control model. Replace Control, and wire accordingly to Figure 3 or Figure 4 on page 16.
	Faulty fuel pump shut-off valve	Replace fuel pump shut-off valve.
	Defective high limit switch or Thermostat	Replace.
	Incorrect fuel nozzle size, nozzle size too big	Contact appliance manufacturer for proper nozzle size, and replace. See page 22 for instructions.
<b>BURNER MOTOR WILL NOT RUN</b>	Overload protector activated	Wait 20 minutes for motor to cool down, will restart automatically.
	Faulty oil primary control. (Applicable only if burner comes with oil primary control).	Observe burner sequence of operations. Check voltage going to the burner motor if it does not run during the 15 second trial for ignition, replace control.
	Fuel pump seized	Replace fuel pump. See Figure 1 on page 13 for replacement parts
	Burner fan loose or misaligned	Identify fan part number by measuring O.D of fan then reference Table 1 on page 14 and position the fan spacing according to Figure 26 on page 36 and tighten set screw.
	Defective control switch	Replace switch.
	Loose wire	Check and replace or tighten wiring.
	Defective burner motor	Replace motor.
<b>BURNER STAYS ON WHEN NO CALL FOR HEAT</b>	Faulty oil primary control. (Applicable only if burner comes with ignition control).	Observe burner sequence of operations. Replace control if necessary
	Thermostat defective	Check for proper operation, replace if necessary.
	Fuel solenoid defective	Replace fuel solenoid.



Troubleshooting tables on pages 10-10 are specific to burners that come equipped with an oil primary control, and these sections only apply if the general troubleshooting guide tells the licensed contractor to consult these sections while servicing the burner.

**NOTE:** This section refers to Honeywell R7284 and R8184 series controls. The R7284G and R8184G control use a LED light to display the troubleshooting status, and the R7284P control comes with a display screen that will output the current operating state of the burner or any troubleshooting errors that might arise in normal burner operation.

**BURNER DOES NOT LIGHT, HONEYWELL CONTROL REMAINS ON STANDBY**

Procedure	Status	Corrective Actions
1. Make sure limit switches are closed	-----	-----
2. Check for line voltage power at primary Control. 120 vac.	-----	<ul style="list-style-type: none"> <li>• Check breaker and investigate appliance wiring</li> </ul>
3. Check R7284G or R8184G indicator light, (LED Screen if R7284P control) with burner off, no call for heat. No Flame.	R7284G & R8184G indicator light is pulsing (1/4 sec. ON, 4 sec. OFF), R7284P display would say "STANDBY"	<ul style="list-style-type: none"> <li>• Sees external light during safety check or connections are shorted,</li> </ul>
4. Shield cad cell from external light	R7284G & R8184G indicator light starts pulsing (1/4 sec. ON, 4 sec. OFF), R7284P display will read "STANDBY"	<ul style="list-style-type: none"> <li>• Energize thermostat to verify that burner goes through proper sequence of operations.</li> <li>• If burner does not light go to step 5</li> </ul>
5. Jumper oil primary T-T terminals	Burner starts	<ul style="list-style-type: none"> <li>• Trouble in thermostat or limit circuit. Check wiring connections</li> </ul>
	Burner does not start	<ul style="list-style-type: none"> <li>• Disconnect line voltage and open thermostat or limit switch.</li> <li>• If burner does not start, replace primary control.</li> </ul>

**BURNER WILL LIGHT, BUT WILL NOT STAY LIT DURING "CALL FOR HEAT"**

Procedure	Status	Corrective Actions
1. Check limit switches	-----	-----
2. Check for line voltage at the oil primary control (120 volts)	-----	-----
3. Check R7284G or R8184G indicator light, (LED Screen if R7284P control) with burner on, call for heat.	R7284 or R8184 control is in lockout. The R7284G & R8184G control LED flashes for ½ seconds ON, ½ seconds OFF. The R7284P control reads "Lockout Mode"	<ul style="list-style-type: none"> <li>Control is sensing bad flame signal, cad cell or controller is defective, sees external light or connections are shorted. Go to step 5.</li> </ul>
	The R7284P display reads "Valve on Delay"	<ul style="list-style-type: none"> <li>Go to step 4.</li> </ul>
4. Applications with "valve on delay", verify that oil valve is closed during the "valve on delay" period by opening view port and verifying that no flame is present during 15 second "valve on delay"	R7284P display still reads "Valve on Delay"	<ul style="list-style-type: none"> <li>If flame is present, replace valve.</li> </ul>
5. Jumper oil primary T-T terminals	Burner starts, and stays running.	<ul style="list-style-type: none"> <li>Trouble is in thermostat or limit circuit.</li> </ul>
	Burner starts, but doesn't stay running.	<ul style="list-style-type: none"> <li>Disconnect line voltage and open thermostat or limit switch.</li> <li>Check all wiring connections</li> <li>If burner does not stay running, go to step 6</li> </ul>
6. Check that nozzle size is per appliance manufacturer recommendation	Burner nozzle incorrect.	<ul style="list-style-type: none"> <li>Change nozzle and fuel pressure to factory settings and retest, if burner doesn't stay lit go to step 7</li> </ul>
	Burner nozzle correct	<ul style="list-style-type: none"> <li>Go to step 7</li> </ul>
7. Check burner air band setting is set up per manufacturer recommendation	Burner air band setting too low.	<ul style="list-style-type: none"> <li>Could cause black puff of smoke on ignition if the fuel-air mixture is too rich.</li> <li>Use a combustion test kit to measure the CO<sub>2</sub> % and smoke spot in the exhaust.</li> <li>Adjust air band opening until CO<sub>2</sub> % measures between 10-12 %, and smoke spot is a 1 or less.</li> <li>If problem persists go to step 8</li> </ul>
	Burner air band setting too high	<ul style="list-style-type: none"> <li>Could cause delayed ignition on start-up if the fuel-air mixture is too lean.</li> <li>Use a combustion test kit to measure the CO<sub>2</sub> % and smoke spot in the exhaust.</li> <li>Adjust air band opening until CO<sub>2</sub> % measures between 10-12 %, and smoke spot is a 1 or less.</li> <li>If problem persists go to step 8</li> </ul>
	Burner air band set at manufacturers recommendations	<ul style="list-style-type: none"> <li>Go to step 8</li> </ul>

<p>8. Check cad cell sighting for view of flame.</p> <ul style="list-style-type: none"> <li>- Disconnect line voltage power and open line switch.</li> <li>- Unplug cad cell and clean face with soft cloth. Check sighting for view of flame. Place cad cell back in socket.</li> <li>- Reconnect line voltage and close line switch.</li> <li>- Start burner,</li> </ul>	<p>Burner locks out.</p>	<ul style="list-style-type: none"> <li>• Go to step 9</li> </ul>
	<p>Burner keeps running, until "call for heat" is satisfied.</p>	<ul style="list-style-type: none"> <li>• System is okay.</li> </ul>
<p>9. Check Control &amp; Cad cell.</p> <ul style="list-style-type: none"> <li>- Remove cad cell wires from connectors on primary and leave lead wires open.</li> <li>- Apply power to device</li> <li>- Place jumper across cad cell terminals after burner motor turns on.</li> </ul>	<p>Burner doesn't run.</p>	<ul style="list-style-type: none"> <li>• Replace primary control.</li> </ul>
	<p>Burner runs.</p>	<ul style="list-style-type: none"> <li>• Control is okay, replace cad cell.</li> </ul>

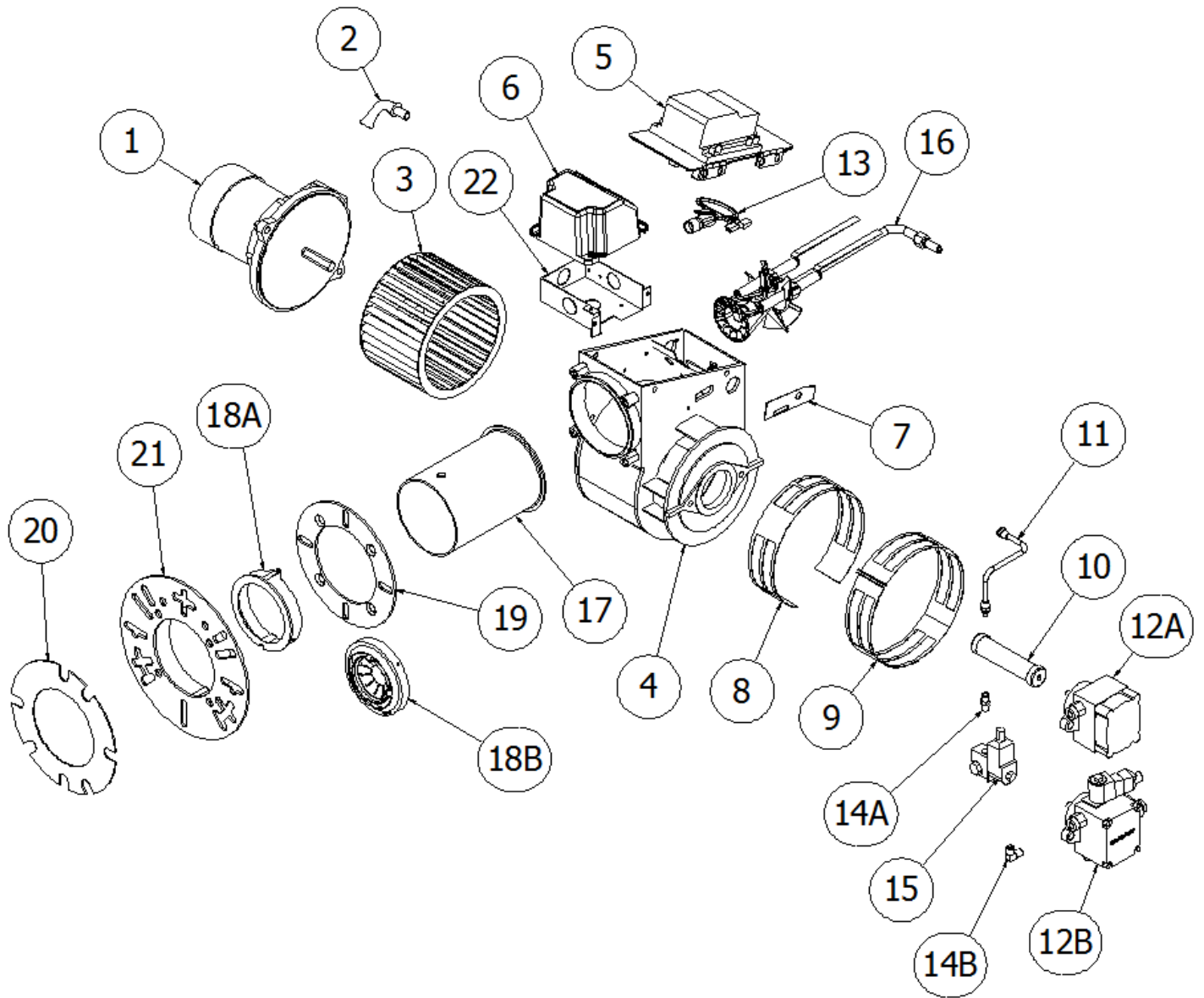


Figure 1- Burner Components – Models EHASR, EHA, and EH

**Table 1- EHASR, EHA, and EH Replacement Parts**

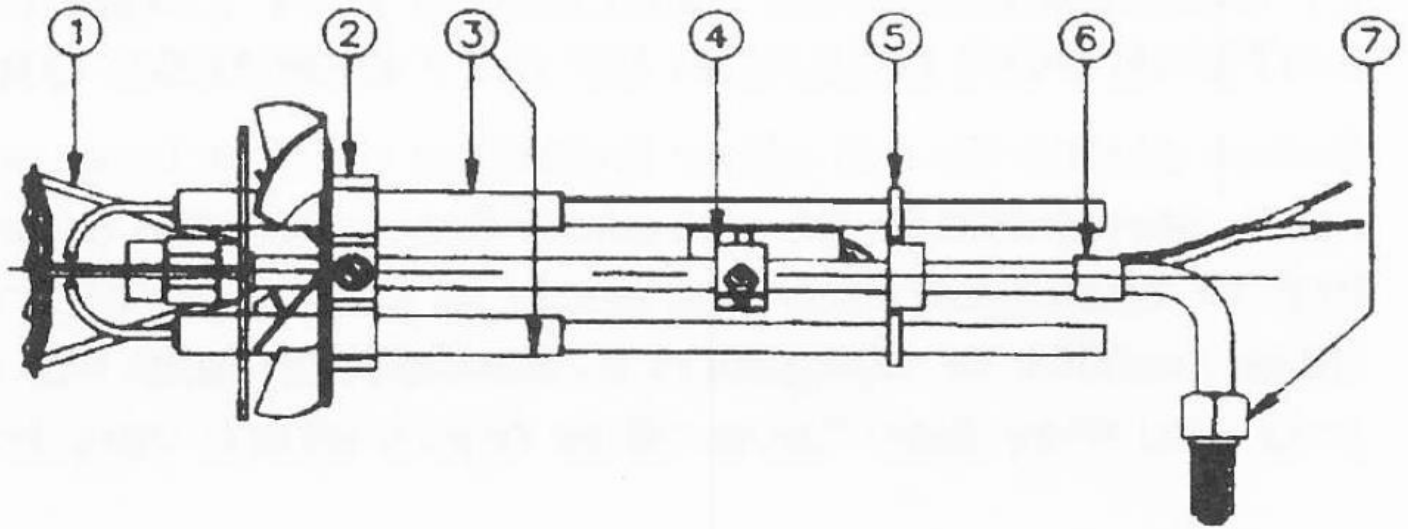
No.	Description	EHA	EH	EHASR
1	Motor - 1/5 HP, 120V PSC	24003-001	●	24003-001
	Motor - 1/5 HP, 120V Cap Start	21569	●	21569
	Motor - 1/4HP, 120V PSC	24005-001	24005-001	24005-001
	Motor - 1/4 HP, 120V Cap Start	21126	21126	●
	Motor - 1/5 HP, 230V PSC	24006-001	●	24006-001
	Motor - 1/4HP, 230V PSC	24004-001	24004-001	24004-001
2	Motor Cord Cover	13121	13121	13121
3	Fan - 5 1/4" Outer Diameter	20288	20288	20288
	Fan - 5 3/4" Outer Diameter	20887	20887	20887
	Fan - 6 1/4" Outer Diameter	21854	21854	21854
4	Burner Housing - Painted	20372	20372	20372
5	120V Ignitor-Iron Core	23101-E	23101-E	23101-E
	230V Ignitor-Iron Core	23103-E	23103-E	23103-E
	120V Ignitor-Solid State	101295-SERE	101295-SERE	101295-SERE
	230V Ignitor-Solid State	101391-SERE	101391-SERE	101391-SERE
6	120V Control - 15 second, Honeywell R7284G	101343-SER	101343-SER	101343-SER
	230V Control - 15 second, Honeywell R8184G	●	100490-001	●
	120V Control - 15 second, Honeywell R7284P	101278-SER	101278-SER	101278-SER
7	Slot Cover Plate	13392	13392	13392
8	Air Band - Inner 8 Slot	2669-002	2669-002	2669-002
9	Air Band - Outer 8 Slot	2668-002	2668-002	2668-002
	Air Band - Outer 5 Slot	20310-002	●	20310-002
10 4)	Coupling - A/B Pump	13279	13279	13279
	Coupling w/ set screws - A/B Pump	100838-001	●	●
11 4)	Oil Line Assembly	14452	14452	14452
12A 3)	Pump - A2VA-7116	13495	●	13495
12A 3)	Pump - A2YA-7916	●	14375-SER	●

No.	Description	EHA	EH	EHASR
12B 2)	Pump - A2VA-3006/120V SOL.	●	●	101128-009
12B 2)	120V Solenoid Valve- A2VA-3006 pump	●	●	100885-001
12B 2)	Pump- A2VA-3006/230V SOL.	●	●	101128-010
12B 2)	230V Solenoid Valve- A2VA-3006 pump	●	●	100885-002
13	Cad Cell - Up to 12" Tube	14289-KIT	14289-KIT	14289-KIT
	Cad Cell - 12" + Tubes	13666-KIT	13666-KIT	13666-KIT
14A 3)	Brass Connector	14222	14222	14222
14B 3), 4)	Brass Connector 90° Elbow	13494	13494	13494
15 3)	120V Solenoid Valve	100610-001	100610-001	100610-001
	230V Solenoid Valve	100610-002	100610-002	100610-002
16	Gun Assembly	(See NOTE Below)		
17	Air Tube	(See NOTE Below)		
18A 1)	Cast Iron - 2 3/4" No Vane	13002	●	●
18A 1)	Cast Iron - 3" No Vane	12989	12989	●
18A 1)	Cast Iron - 3 1/4" No Vane	12990	12990	●
18A 1)	Cast Iron - 3 9/16" No Vane	●	13003	●
18B 1)	Stainless - SR #1A	●	●	14157
18B 1)	Stainless - SR #2A	●	●	14158
18B 1)	Stainless - SR #3A	●	●	14159
18B 1)	Stainless - SR #4A	●	●	14160
19	Flange	21426	21426	21426
20	Gasket	12484	12484	12484
21	Adjustable Flange	2689-SER	2689-SER	2689-SER
22	Junction Box	21319	21319	21319
Not Shown	Pedestal	2794-011	2794-011	2794-011
Not Shown	Tune-Up Kit	31156	31156	31156

**NOTE: STATE SPECIFICATION NUMBER, BURNER MODEL, PART DESCRIPTION AND PART NUMBER WHEN ORDERING PARTS**

- 1) Cast Iron Cones - Measure machined ID. Stainless Steel Air Cones - Number/Letter combination stamped into face of outer ring.
- 2) Item 12B are oil pumps that come with oil solenoid valves already attached, but replacement parts are available for replacing the fuel solenoid.
- 3) Item 12A are oil pumps that do not come with solenoid valves, solenoid valves are optional for these model. If oil pump comes with a solenoid valve (item 15), item number 14A must be used. If oil pump does not come with a solenoid valve, brass connector elbow 14B must be used.
- 4) Part included in 31156 Tune-Up Kit

●= Item not available for purchase on that specific burner model



**Figure 2– Oil Gun Assembly Detail View**

(Parts not necessarily as shown)

**Table 2- Oil Gun Replacement Parts**

No.	Part Description	EHA	EH	EHASR
1	Nozzle Adaptor	12988-002	12988-002	21913-SER
2	Stamped Stabilizer Support Kit	21923-001	21923-001	21923-001
	Cast Stabilizer Support Kit	21408-SER	21408-SER	21408-SER
3	Stem/Insulator Kit	13286	13286	13286
4	Cad Cell Mount	13078	13078	13078
5	Buss Bar Support	13276-002	13276-002	13276-002
6	Cad Cell Wire Tie	100850-001	100850-001	100850-001
7	Oil Pipe Fitting	14295-002	14295-002	14295-002

# WIRING DIAGRAMS

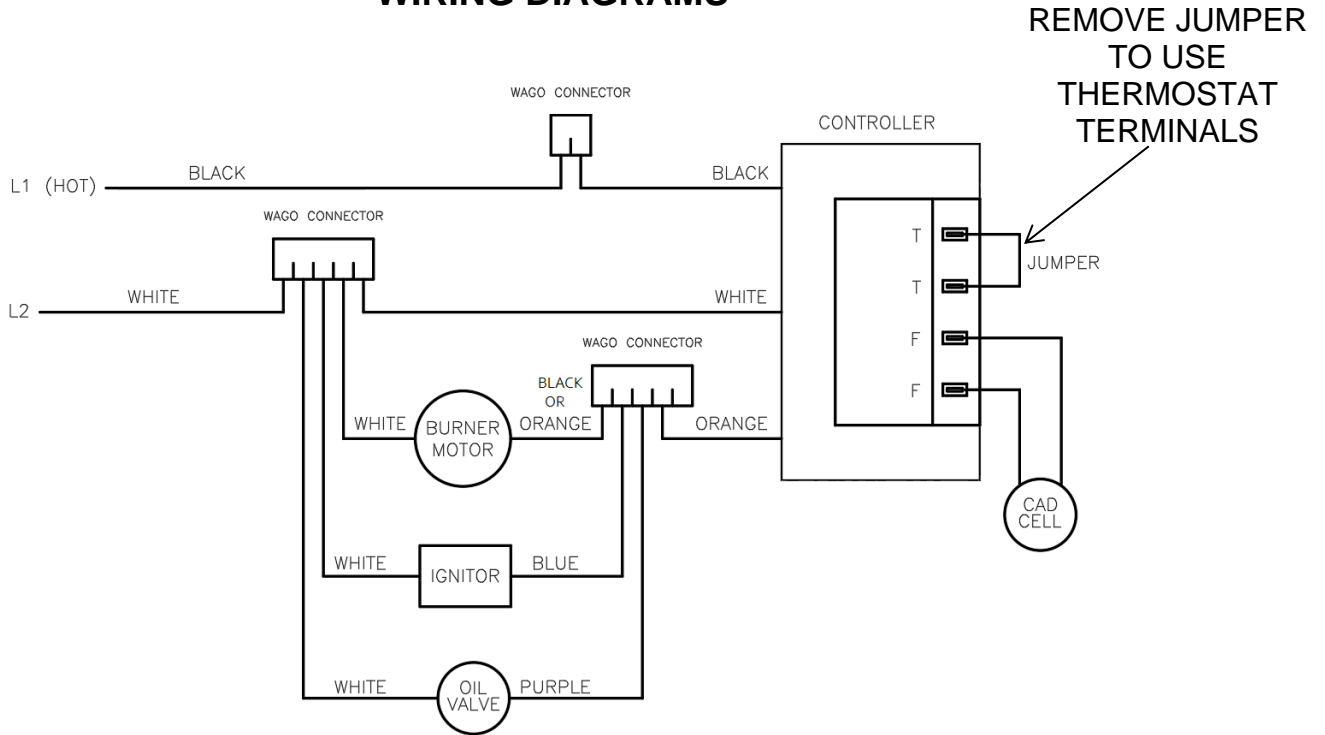
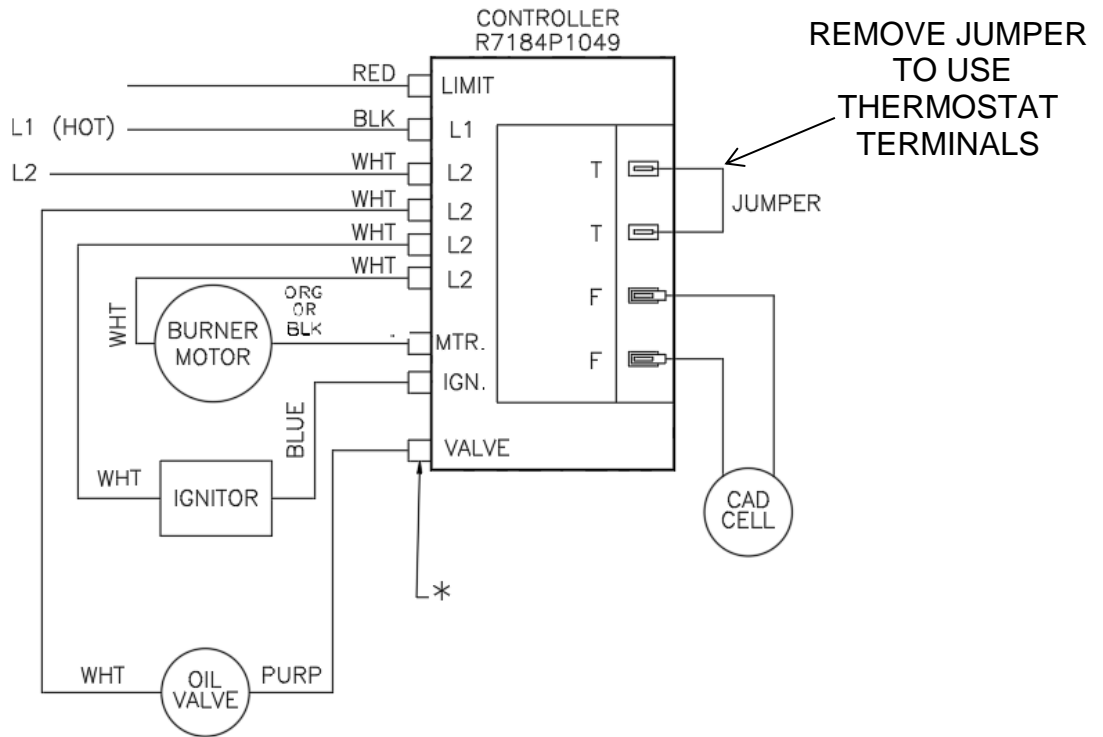


Figure 3- Wiring Diagram for 120V Honeywell R7284G & 230V Honeywell R8184G Controls



\* - DENOTES A 1/4" 90° INSULATED FEMALE TERMINAL THAT NEEDS TO BE CRIMPED ON EACH COMPONENT LEAD.

Figure 4- Wiring Diagram for 120V Honeywell R7284P Control



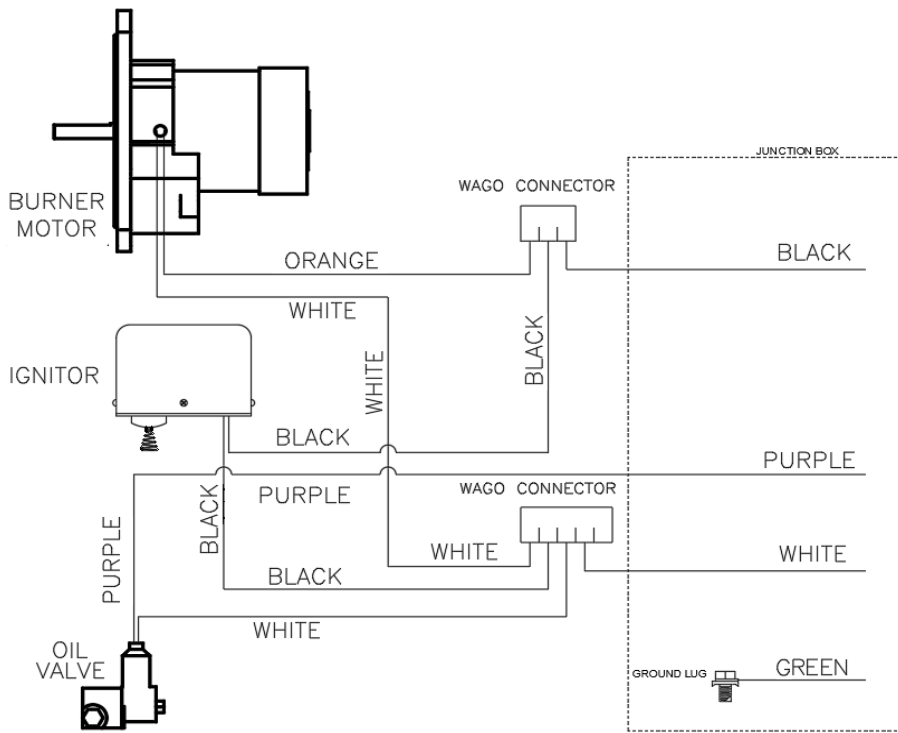


Figure 5- Wiring Diagram for 120/230V Burners without a control

## SEQUENCE OF OPERATION: BURNERS WITH R7284G AND R8184G CONTROLS

### BURNER OPERATION

On every call for heat the oil primary control performs an internal safety check which takes five seconds to complete. During these five seconds, the oil primary control verifies that the cad cell is outputting a “no flame” resistance value. After the check, the oil primary control will simultaneously energize the burner blower motor, solenoid valve (if equipped), and ignition device. The control will then enter the 15 second trial for ignition period; once flame is established the oil primary control will continue to monitor the flame by using the cad cell’s resistance value. The oil primary control allows burner operation to continue until the thermostat control’s “call for heat” is satisfied. Once the thermostat is satisfied the burner will be de-energized. If flame is not detected during the trial for ignition, the oil primary control will go into a “lock-out” condition. If this occurs, proceed to the section titled SAFETY LOCK-OUT TIME.

### SAFETY LOCK-OUT TIME

Ignition failure occurs during the first “trial for ignition” period

The cad cell monitors the combustion chamber for flame during the burner’s trial for ignition period. If no flame is detected the oil primary control will go into a lockout condition. When the oil primary control goes into lockout it will de-energize the burner, and the control’s LED light will flash ½ sec on, and ½ sec off. Before attempting to start the burner again the control must be reset. Press and hold the “i” button for three seconds to reset the control. If normal ignition does not occur see **GENERAL TROUBLESHOOTING GUIDE** on page 7.

#### **NOTICE**

Do not keep pressing the reset button and restarting the burner more than once with the burner not lighting this could cause oil buildup in the firing chamber. This will cause smoking and possible detonation that could damage the equipment if the burner does light.

Intermittent flame failure occurs during a “call for heat”

If the oil primary control stops sensing a flame after the flame has been proven and the trial for ignition timer has expired, the oil primary control enters a limited recycle mode where it will de-energize the burner for one minute, while the LED light will flash for 2 seconds on, and 2 seconds off. After one minute the oil primary control resumes the call for heat, and enters another “trial for ignition” period. If a flame is proven during the trial for ignition, and lost after the trial for ignition timer expires the control will go into another recycle mode countdown. If no flame is proven during the trial for ignition period the control will go into a lockout condition. If the control tries three recycle modes where flame is proven, and then subsequently lost the control will go into a hard lockout condition de-energizing the burner. If normal ignition does not occur see **GENERAL TROUBLESHOOTING GUIDE** on page 7.

## SEQUENCE OF OPERATION: BURNER WITH R7284P CONTROL

### BURNER OPERATION

On every call for heat the oil primary control performs an internal safety check which takes five seconds to complete. During these five seconds, the oil primary control verifies that the cad cell is outputting a “no flame” resistance value. After the check, the oil primary control will simultaneously energize the burner blower motor, solenoid valve (if equipped), and ignition device. The oil primary control will then enter the 15 second trial for ignition period; once flame is established the oil primary control will continue to monitor the flame by using the cad cell, and it will de-energize the ignitor after 10 seconds. The oil primary control allows burner operation to continue until the thermostat control’s “call for heat” is satisfied. Once the thermostat is satisfied the burner will be de-energized. If flame is not detected during the trial for ignition, the oil primary control will go into a “lock-out” condition. If this occurs, proceed to the section titled SAFETY LOCK-OUT TIME.

### SAFETY LOCK-OUT TIME

Ignition failure occurs during the first “trial for ignition” period

The cad cell monitors the combustion chamber for flame during the burner’s trial for ignition period. If no flame is detected the oil primary control will go into a lockout condition. When the control goes into lockout it will de-energize the burner, and the control’s screen will display “lockout mode”. Before attempting to start the burner again the control must be reset. Press and hold the “i” button for three seconds to reset the control. If normal ignition does not occur see **GENERAL TROUBLESHOOTING GUIDE** on page 7.

#### **NOTICE**

Do not keep pressing the reset button and restarting the burner more than once with the burner not lighting this could cause oil buildup in the firing chamber. This will cause smoking and possible detonation that could damage the equipment if the burner does light.

Intermittent flame failure occurs during a “call for heat”

If the oil primary control stops sensing a flame after the flame has been proven and the trial for ignition timer has expired, the oil primary control enters a limited recycle mode where it will de-energize the burner for one minute while displaying “recycle” on the display screen. After one minute the oil primary control resumes the call for heat, and enters another “trial for ignition” period. If a flame is proven during the trial for ignition, and lost after the trial for ignition timer expires the oil primary control will go into another recycle mode countdown. If no flame is proven during the trial for ignition period the oil primary control will go into a lockout condition. If the oil primary control tries three recycle modes where flame is proven, and then subsequently lost the control will go into a hard lockout condition de-energizing the burner. If normal ignition does not occur see **GENERAL TROUBLESHOOTING GUIDE** on page 7.

# SEQUENCE OF OPERATION: BURNER WITHOUT CONTROL

## BURNER OPERATION

If the burner is controlled by a high voltage limit switch on the incoming power line to the burner, the operation of the burner is a simple ON/OFF mechanism, where all the burner components will be energized simultaneously to fire the burner. If any problems arise during ignition or continued operation of the burner see the **GENERAL TROUBLESHOOTING GUIDE** on page 7.

## OPERATIONAL CHECK OF BURNER



### **WARNING**

Make sure combustion chamber is free of oil or oil vapor before starting system.

### START SYSTEM

- Open hand valve in oil supply line.
- Make sure system is electrically energized, check circuit breaker, fuses, and close system switch if provided.
- Press and hold the oil primary control i button for two seconds and release (big red button for three seconds for old Wayne control).
- Set thermostat (controller) to “call for heat”.
- Burner should light and operate until call for heat is satisfied.

### CHECK SAFETY FEATURES

#### Simulate flame failure

- Follow starting procedures to turn on burner.
- Close hand valve on supply line, stopping fuel delivery to the burner.
- The oil primary control should lockout after control’s trial for ignition timer expires. The burner blower motor and ignition device should stop, and the solenoid valve should close.

#### Simulate ignition failure

- Close hand valve on supply line, stopping fuel delivery to the burner.
- Follow starting procedures to turn on burner.
- Oil primary control should lockout after control’s trial for ignition timer expires. The burner blower motor and igniter should stop, and the solenoid valve should close.

#### Simulate power failure

- With burner running, turn off power supply to the system.
- Burner should stop.
- Restore power, burner should start.

If system does not operate as described, proceed to **GENERAL TROUBLESHOOTING GUIDE** on page 7

## GENERAL INSTALLATION INFORMATION

When installing the burner, be sure to provide adequate space for easy service and maintenance. Prior to installation of the oil burner, the heating system should be carefully inspected for defects and cleanliness. The flue passages and heat absorbing surfaces must be clean to ensure maximum heat transfer. Soot acts as an insulator, which retards the transfer of heat. The combustion chamber, flue gas passages, and all doors and openings must be tightly sealed to eliminate air infiltration. Excess air cools the flame and thus lowers efficiency. Inspect the flue and chimney for leaks and obstructions. Be sure the chimney is of adequate size and height. Install a draft regulator the same size as the flue pipe (see paragraph under DRAFT REGULATORS).

### COMBUSTION CHAMBER

The purpose of a combustion chamber is to maintain a high flame temperature by reflecting the heat back into the flame. A high flame temperature assures greater combustion efficiency and lower stack losses. An insulating refractory or a Fiber Fax type chamber can be used with this burner. It is important to select and install, the correct nozzle size for a given combustion chamber size (see Table 4 on page 35). On all oil burners the atomized oil must not touch the sides or bottom of the combustion chamber or improper combustion will occur leading to smoke and soot build-up. To reduce smoke while the burner is running, the burner must have an adequate supply of combustion air by having a large enough opening on the air band assembly. If too much air is utilized it can lead to high gas exhaust temperatures, and lower combustion efficiency. Install the burner so the face of the air cone on the burner is set a ¼ inch behind the inside front wall of the chamber (see Figure 20 on page 30).

### FUEL PUMPS

Model EHASR, EHA and EH oil burners are provided with single stage 3450 RPM fuel pumps with the by-pass plug removed for a single pipe installation. This is satisfactory where the fuel supply is on the same level, or above burner, permitting gravity flow of oil.

#### **NOTICE**

Never exceed 3 PSI pressure to the suction side of the fuel pump. A pressure over 3 PSI may cause damage to the shaft seal and allow it to leak oil.

When it is necessary to lift the oil to the burner, a return line should be run between the fuel pump and oil tank. (If lift exceeds 10 feet, a two stage fuel pump must be used with a return line). When a two line installation is made, the by-pass plug must be installed. This is supplied with the burner attached to fuel pump, along with a pump data sheet in a plastic bag.

#### **NOTICE**

Do not install by-pass plug if running single pipe operation, this will over-pressurize the pump causing an oil leak at the pump shaft seal.

### FUEL LINES

When oil lines are continuous runs, heavy wall copper tubing is recommended for the fuel lines. Be sure that all connections are absolutely air-tight. Check all connections and joints. Flared fittings are recommended. Do not use compression fittings. Avoid running tubing against the appliance and across ceiling or floor joist; if possible install under floor. Avoid using fittings in inaccessible locations. If possible, avoid running oil lines overhead. Specific information on piping, connections, lift capabilities and tank installations is provided in the instruction sheet of the fuel pump manufacturer, however if the instruction gets damaged or unreadable see oil pipe sizing information under reference information on page 37. Install an UL certified oil filter of adequate size for all installations.

## FUEL TANKS

Local codes and regulations must be followed regarding tank and burner installation. Check existing tanks for water and sludge accumulation; clean if necessary. Also clean or replace existing piping.

## ELECTRICAL WIRING OF BURNER

The oil burner is shipped completely wired. It is only necessary to supply the line voltage circuit, thermostat and limit circuit. All wiring must comply with the National Electric Code or the code legally authorized in the locality where the installation is being made. The burner, when installed must be electrically grounded in accordance with local codes or, in absence of local codes, with the latest edition of the National Electrical Code, ANSI/NFPA No. 70. Refer to wiring diagrams Figure 3, Figure 4 and Figure 5 on pages 16 & 17 for reference on wiring, and thermostat connection. If an external electrical source is utilized, the oil burner, when installed, must be electrically grounded in accordance with local codes or, in the absence of local codes, with the latest edition of the National Electrical Code, ANSI/NFPA No. 70.

For line voltage wiring to the burner use solid copper conductor wire not lighter than #14 AWG. **If a fused disconnect is used, it should be fused for a minimum of 20 amps.**

If the oil burner comes equipped with an oil primary control, the burner will be shipped with a jumper wire on the thermostat (T-T) terminals. The jumper needs to be removed for remote thermostat control and the thermostat needs to be connected per wiring diagrams. A T-T terminal is an open/close switch for the oil primary control and no voltage should be connected to it. For boilers it may be necessary to leave the T-T terminal jumped as the aquastat may be providing the voltage to the burner and controlling when voltage is sent to the burner. The burner is controlled by the appliance. Once wiring is complete between burner and appliance, verify that the appliance is controlling the burner's on/off operation. When connecting the burner to the line voltage electrical supply, utilize the knockout provided on the burner's junction box.

### CAUTION



Label all wires prior to disconnection when servicing burners. Wiring errors can cause improper and dangerous operation. Verify proper operation after servicing

### NOTICE

If any of the original burner wiring must be replaced, it must be replaced with #18 AWG 105°C wire or equivalent

## CHIMNEY INSTALLATION

Follow the recommendations of the appliance manufacturer. A chimney shall be capable of producing a draft as recommended by the appliance manufacturer. It must be properly designed, of adequate size, be above the surrounding objects, tile-lined, with no obstructions, and be in a good state of repair. The smoke pipe should sit flush with the inside of the tile and be cemented in place. All cleanout doors should be sealed. A draft inducer may be used to overcome inadequate draft conditions. If a draft inducer is used, provisions must be made to ensure the burner does not operate if the draft inducer fails.

## DRAFT REGULATORS

A draft regulator shall be provided unless otherwise specified by the appliance manufacturer. The draft regulator shall be installed in accordance with local codes and regulations or in the absence of local codes, with ANSI NFPA31. Refer to appliance manufacturer's instructions for recommended over fire and stack draft.

## AIR SUPPLY FOR COMBUSTION

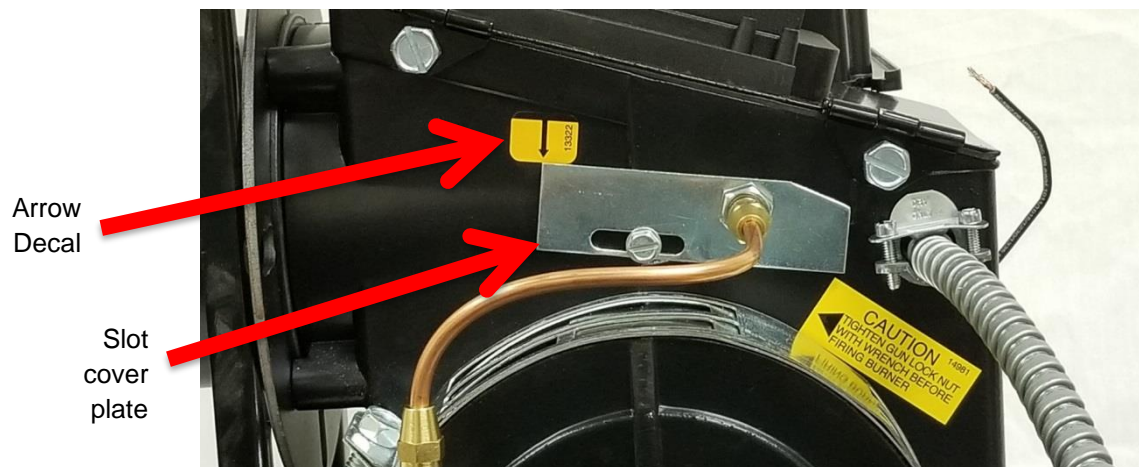
A burner shall not be installed in an area where normal air circulation or infiltration is limited and it restricts the amount of air necessary for proper combustion and venting. When the heating appliance is installed in a confined space, two permanent air openings shall be provided; one near the top of the enclosure and one near the bottom. Each opening shall have a free area of no less than one square inch per 1000 Btu/hr (140 square inch per gal/hr) of the total input rating of all the appliances in the space. When the house is of unusually tight construction, has a kitchen ventilating system, exhaust fans, clothes dryer or vented fireplaces, it is recommended that combustion air be supplied through two permanent openings. The openings should connect directly, or by means of ducts, with outdoors or to such spaces (attic or crawl) that are exposed to the outdoors. For additional information, refer to ANSI standard NFPA31.

## NOZZLE AND AIR CONE SELECTION

The EHASR, EHA, and EH oil burners typically fire well with a solid or semi-solid nozzle with a spray angle of 80, 70, or 60 degrees. In most upgrading or conversion installations, the use of an 80 degree solid nozzle is a good starting point. Always use the proper nozzle size, spray cone type and spray angle the appliance manufacturer recommends. Should this information not be available, your own good judgment will prevail. Under no circumstances attempt to fire the EHA or EHASR oil burners under their 0.75 gal/hr minimum input rating or over their 3.00 gal/hr maximum input rating. Under no circumstances attempt to fire the EH oil burner under its 3.00 gal/hr minimum input rating or over its 6.00 gal/hr maximum input ratings.

## NOZZLE INSTALLATION

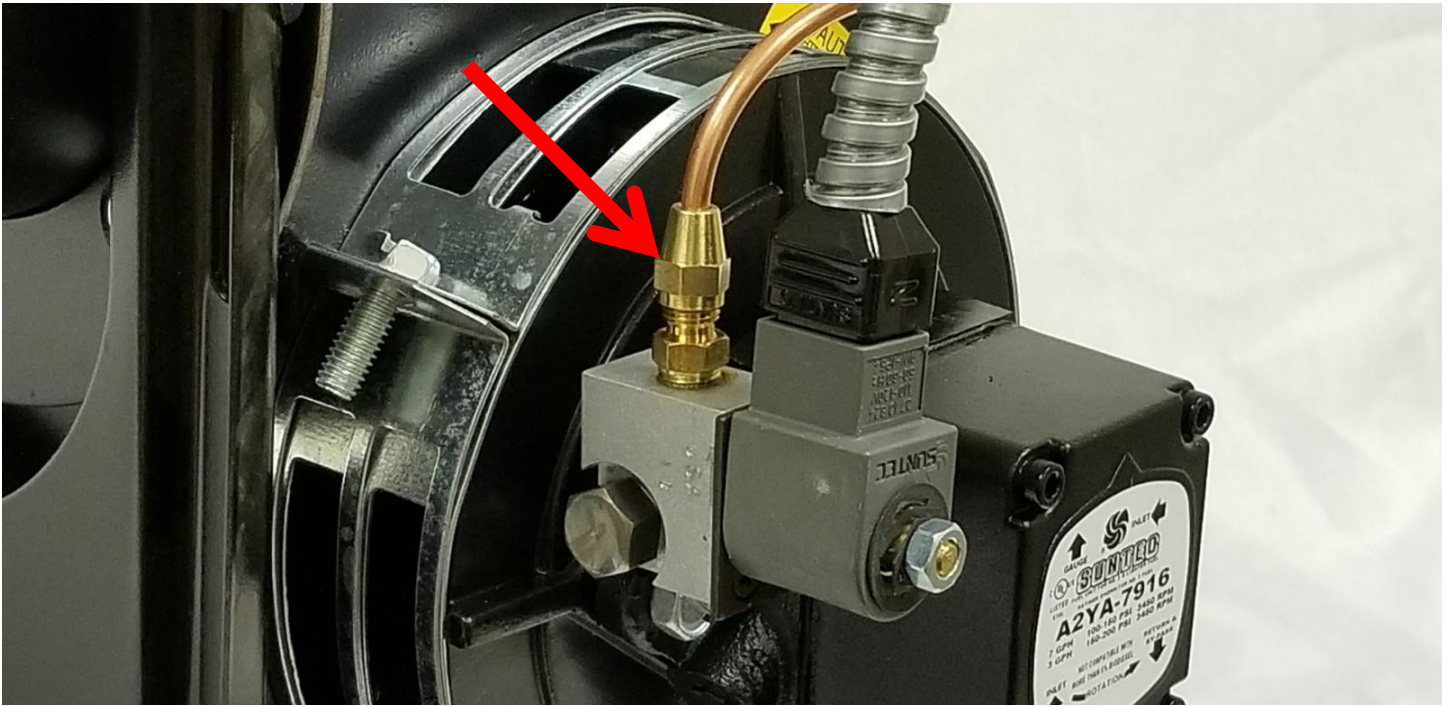
In order to install or change the nozzle, the oil gun assembly needs to be removed from the burner. The EHASR, EHA, and EH burners has an arrow decal that lines up with the leading edge of the oil gun slot cover plate. This will help with re-installing the oil gun in the proper position once the nozzle has been installed. See Figure 6 for part identification.



**Figure 6– EH/ EHASR Side View of Oil Gun Slot Plate Cover**

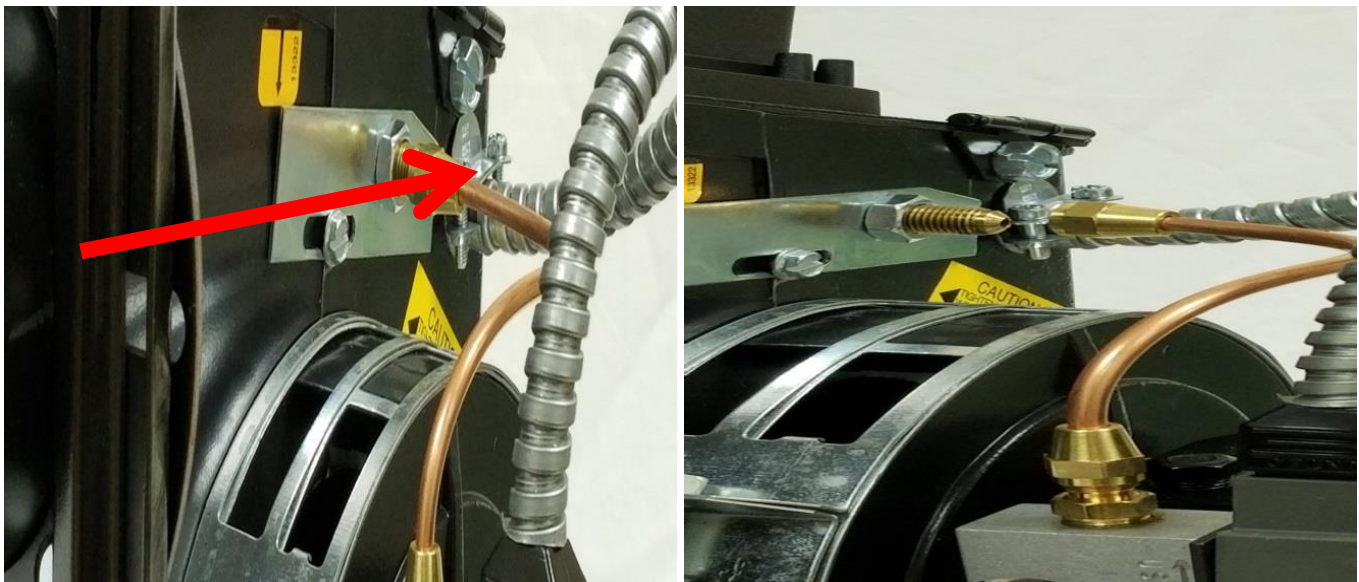
1. Locate the slot plate cover, loosen the brass oil assembly nut with a 7/16 inch wrench at the connection with the brass fitting on the solenoid valve, but do not remove all the way. (Figure 7 on page 23).

Note-For pumps with combination solenoid valves disconnect the oil line from the brass elbow fitting installed in the nozzle port of the pump.



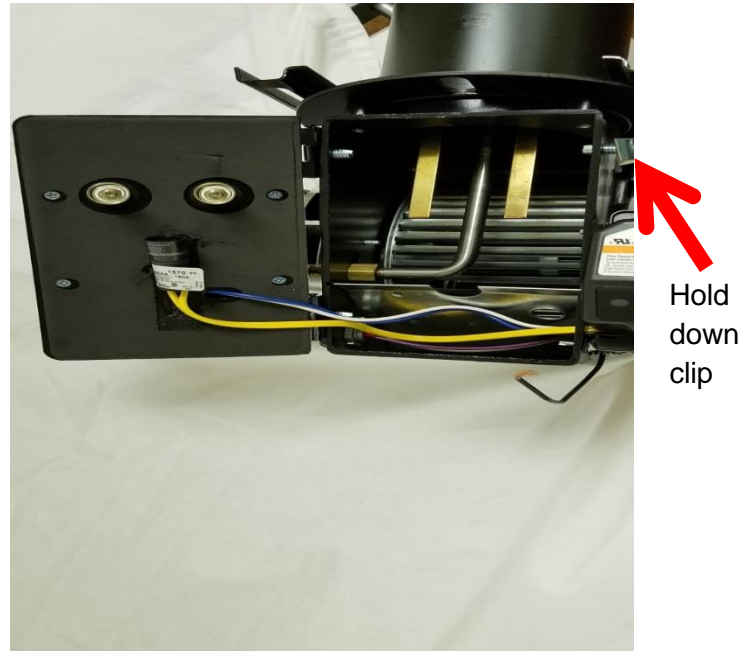
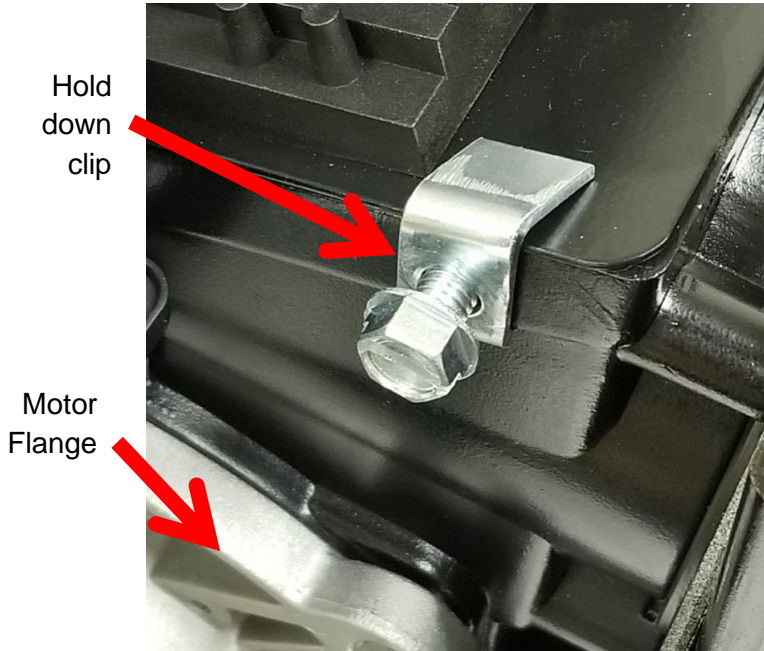
**Figure 7 EH/EHASR Oil Line Assembly Fitting**

2. Loosen and disconnect the brass nut of the copper oil line assembly from the oil gun assembly fitting and rotate the oil line out of the way (Figure 8).



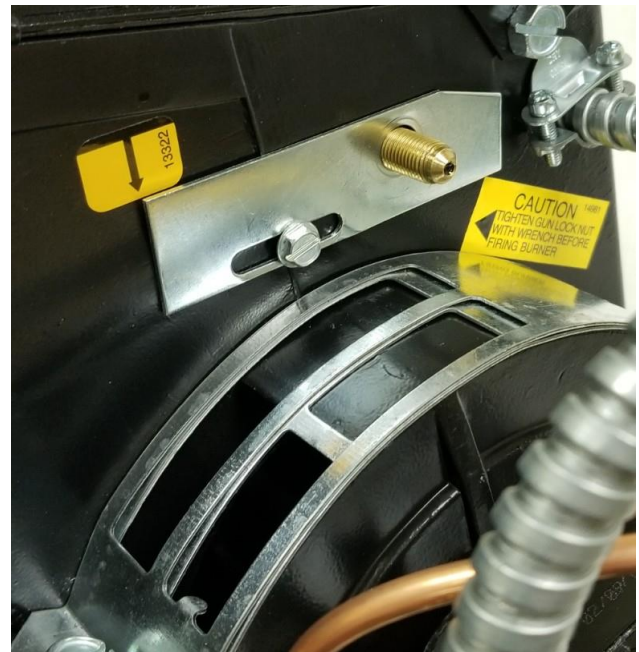
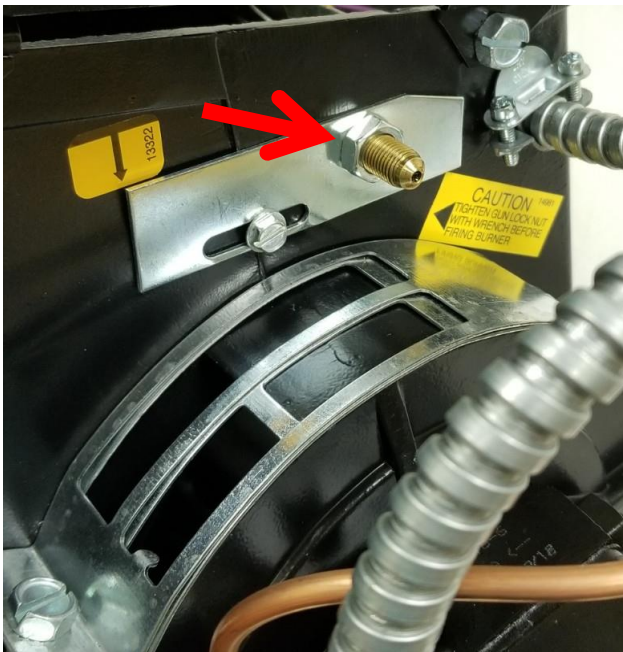
**Figure 8 EH/EHASR Oil Line Removal**

3. Next loosen the ignition device mounting plate clip screw by using a flat head screwdriver, move the hold down clip off of the mounting plate, this will allow the igniter device assembly to swing open to the left. For now leave the plate in the closed position (Figure 9).



**Figure 9 EH/EHASR Ignitor mounting plate screw removal**

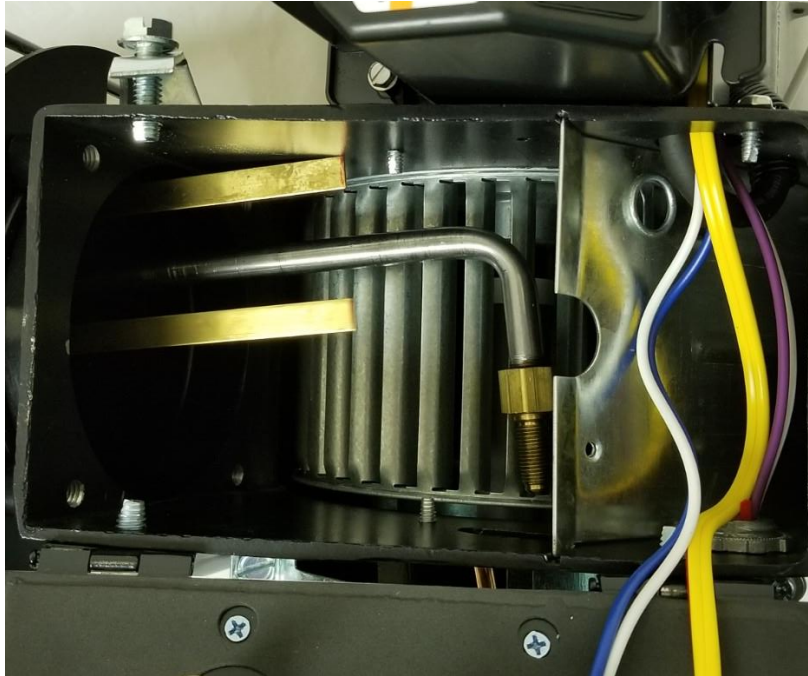
4. Using a 9/16 inch wrench loosen and remove the oil gun assembly locknut (Figure 10).



**Figure 10 EH/EHASR Oil Gun Lock Nut Removal**

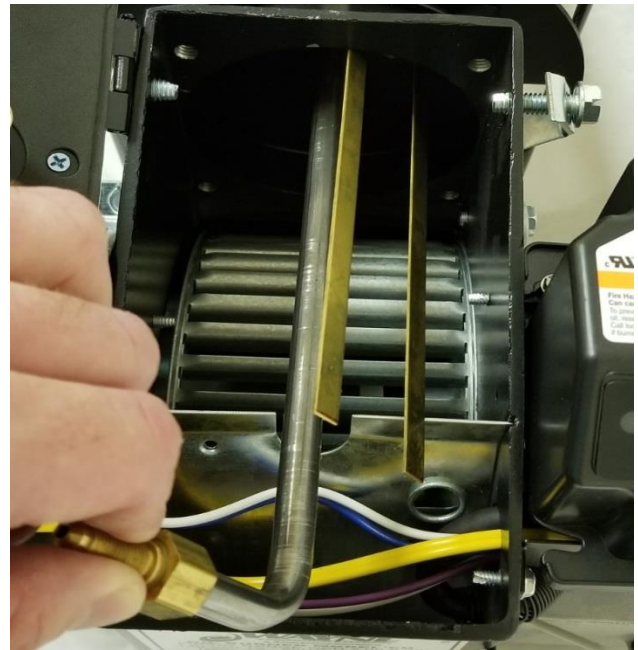
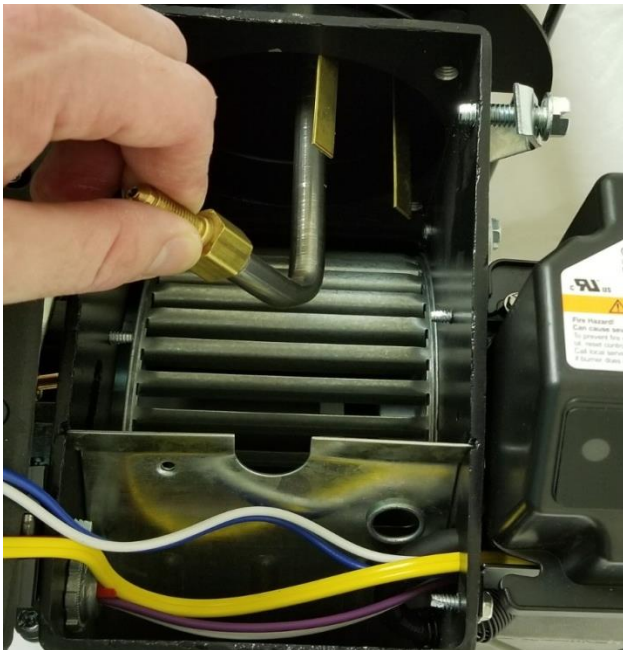


5. Now grasp the rear of the oil gun assembly where the oil line fitting adapter exits through the housing and pull the oil gun to the right out of the housing slot and the slot plate cover (Figure 11).



**Figure 11 EH/EHASR Oil Gun Removal**

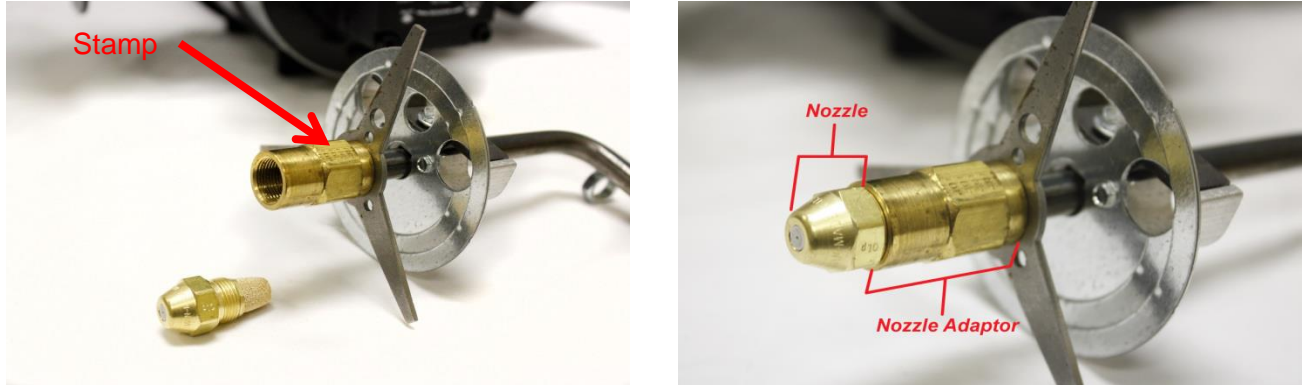
6. While rotating the oil line fitting adapter up at a 45 degree angle, gently lift, but do not force, the entire gun assembly out of the housing opening (Figure 12).



**Figure 12 EH/EHASR Oil Gun Removal (Continued)**

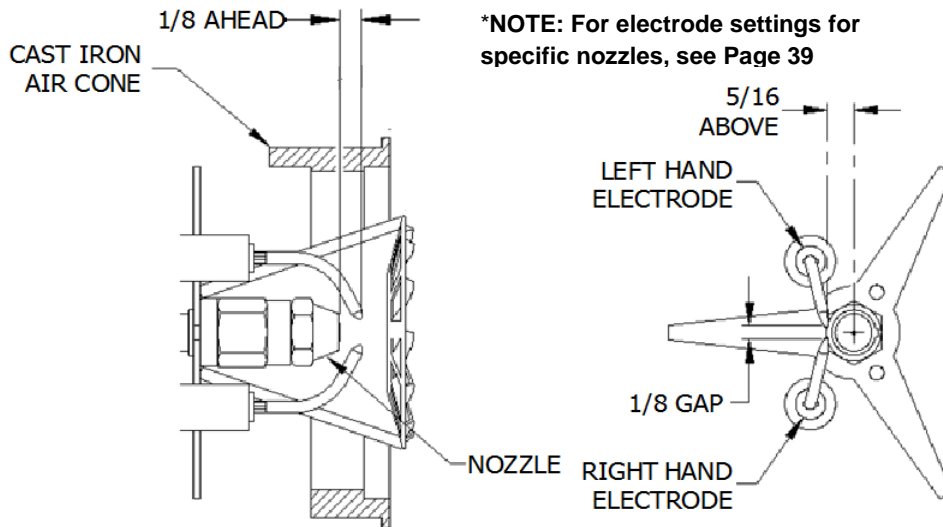
7. Thread the nozzle into the nozzle adaptor finger tight, then tighten the nozzle securely with a 5/8" wrench, while using a 3/4" backing wrench to hold the nozzle adaptor. Do not over tighten. There is a brass stamp that reads "TOP" on the nozzle adaptor that should be orientated up (Figure 13).

<p><b>NOTICE</b></p>	<p>DO NOT touch the new nozzle's filter or touch the face of the nozzle. Oil from your fingers on either surface can adversely affect nozzle performance</p>
----------------------	--

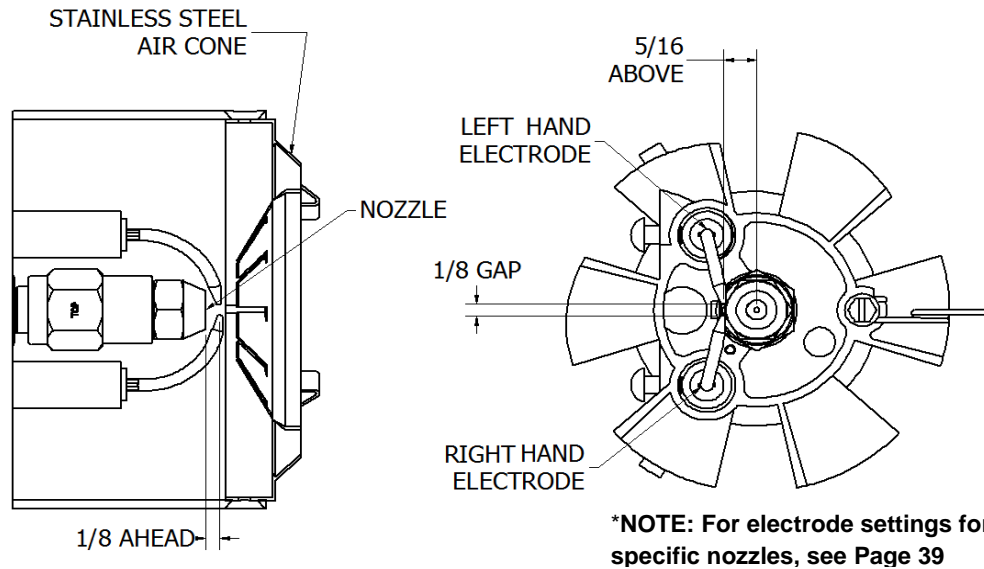


**Figure 13 EH/EHASR Oil Gun Nozzle Installation (Flamelock and electrodes removed for clarity).**

8. Identify which burner model you have, then measure and verify that the electrode spacing is per Figure 14 or Figure 15 on page 27, if not correct to factory settings.



**Figure 14–EH Electrode Positions, Factory settings**



**Figure 15–EHASR Electrode Positions, Factory settings**

- At this time position the gun assembly back into the housing in reverse sequence that gun assembly was removed in, while taking care not to disrupt the electrode spacing.

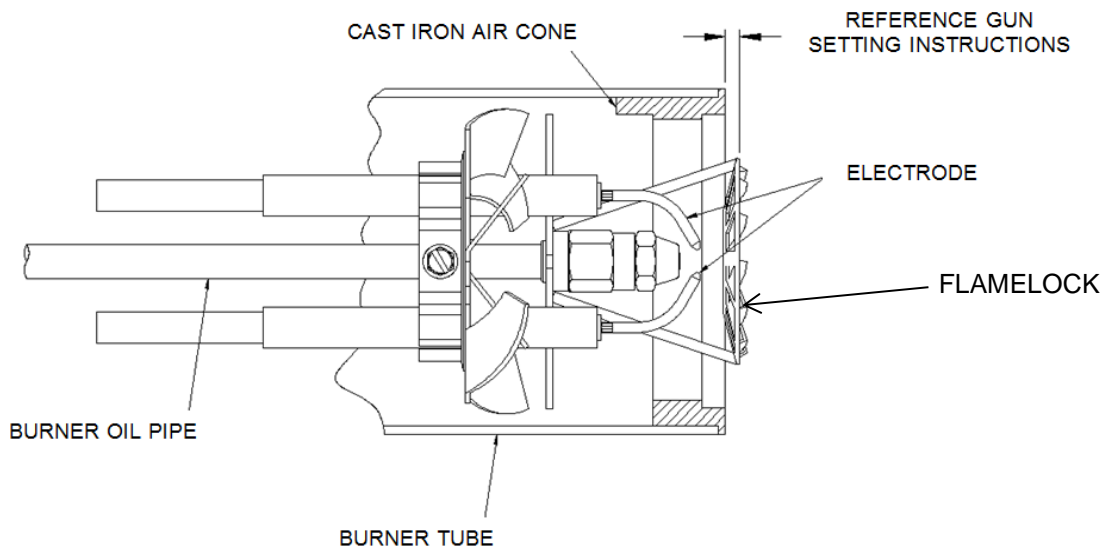
Note: Re-measure electrodes gap after installing gun assembly in burner to verify that the position has not shifted

## SETTING GUN DEPTH

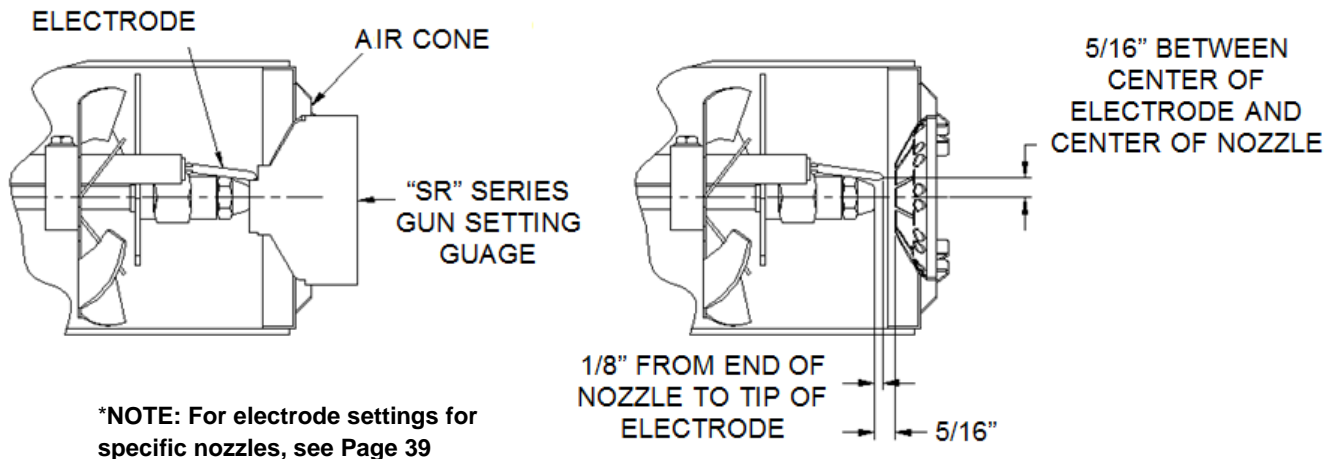
For the oil burner to function properly the distance between the nozzle and the air cone needs to be maintained as shown in Figure 16 & Figure 17 on page 28.

### (For EHA and EH Burners Only)

**Suggested startup setting:** EHA Flamelock flush with cast iron cone face. EH Flamelock 1/8" ahead of cast iron cone face for 3.00 to 4.50 gal/hr or 1/4" ahead for 5.00 to 6.00 gal/hr

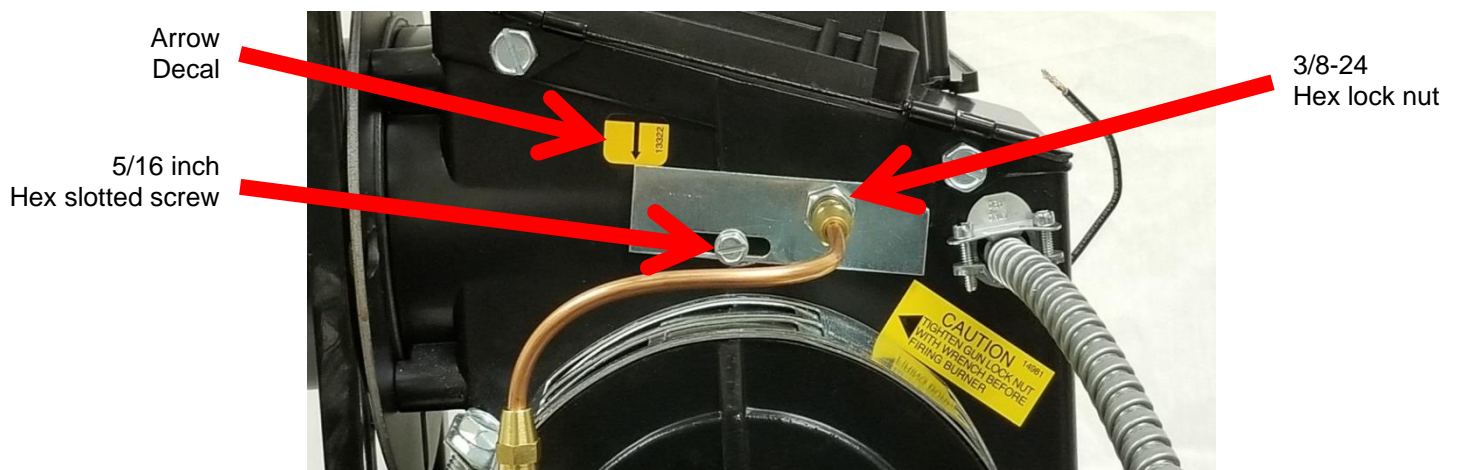


**Figure 16- EHA and EH Gun Depth Settings**



**Figure 17– EHASR Gun Depth Settings**

1. Identify which E burner model you have and set the gun depth accordingly.
2. To position the gun assembly forward or backwards, loosen the gun assembly 3/8-24 hex lock nut with a 9/16 inch wrench and the 5/16 inch hex slotted slot cover screw as shown in Figure 18.



**Figure 18– Oil Gun Depth Adjustment**

3. Once in the required position per Figure 16 and Figure 17, retighten the hex lock nut and slot cover screw, move and align arrow decal with slot plate cover.

**NOTICE**

Close the ignition transformer and assure there is a positive spring contact with the brass buss bars. Take care not to pinch the ignition transformer lead wires between the housing and cover plate. Reinstall the igniter plate hold down clip and tighten the 5/16-18 hex slotted screw securely.

# BURNER INSTALLATION

The EHASR, EHA, and EH oil burners were designed for furnaces, boilers, water heaters and a wide variety of commercial applications ranging from pressure washers & asphalt trucks. The burner is supplied as a completely assembled unit. This burner should be installed into your appliance with the appliance manufacturer's recommendations; if no recommendations are available it is up to the expertise of the installer.

NOTE: The burner must be installed in such a manner that all controls will be readily accessible for inspection, cleaning, adjustment, and repairs.

## INSTALLATION OF MOUNTING FLANGE

Position the mounting flange on the furnace wall, adjusting orientation as necessary until the bolt pattern of the appliance allows the flange to sit flush. (See Figure 19 for flange dimensions.)

Note the orientation of the flange and remove it so that the flange gasket may be placed between the appliance wall and flange. Tighten the flange to the furnace wall.

Insert the burner tube into the flange and position it per Figure 20 on page 30. Tighten the flange onto the burner tube.

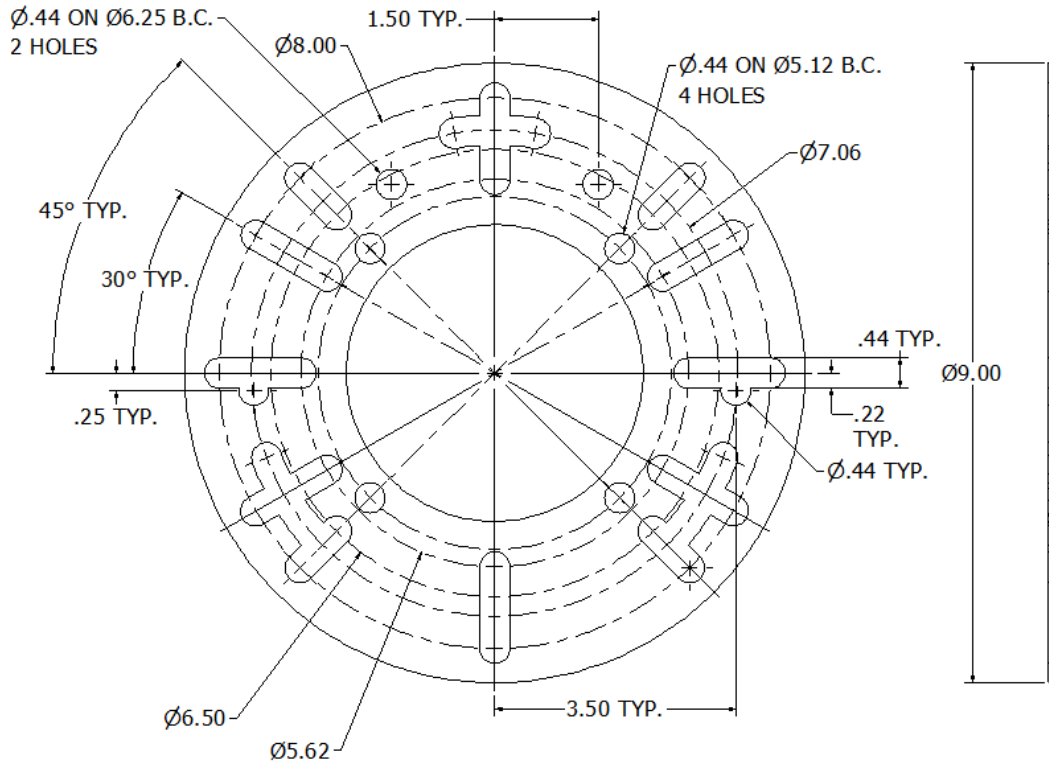
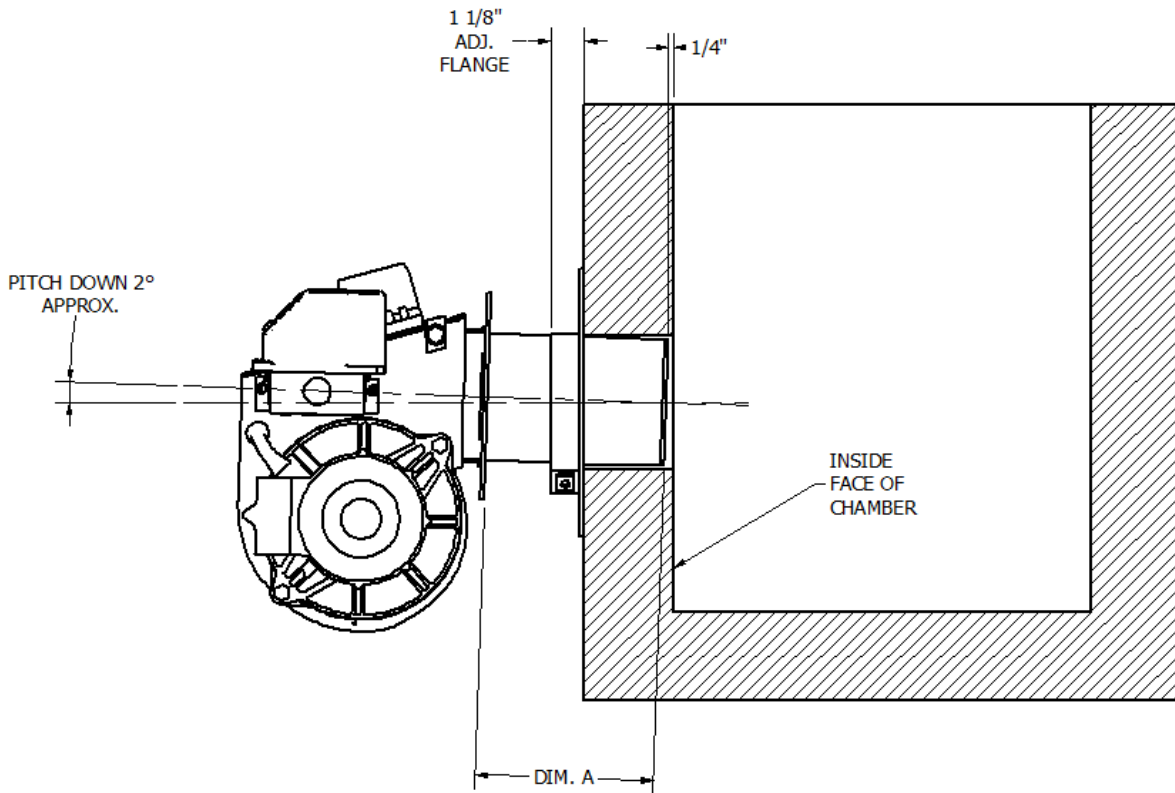


Figure 19– Adjustable Mounting Flange Dimensions



**Figure 20– Combustion Chamber Installation Recommendations**

Note: The air tube length (DIM. A) is the distance from the front of the air tube retainer flange to the air tube cutoff where the air cone mounts in the tube. Note adjustable flange width.

## STARTING PROCEDURE

### STARTING BURNER

Be sure that the electrical breaker to the appliance is in the “OFF” position, set the thermostat to a temperature substantially above room temperature, and ensure the oil tank is filled, all valves are open, and controls set for operation. Adjust air supply on burner by loosening screw on interlocking air bands, and open the air band until black smoke is eliminated on start-up (see Figure 21).

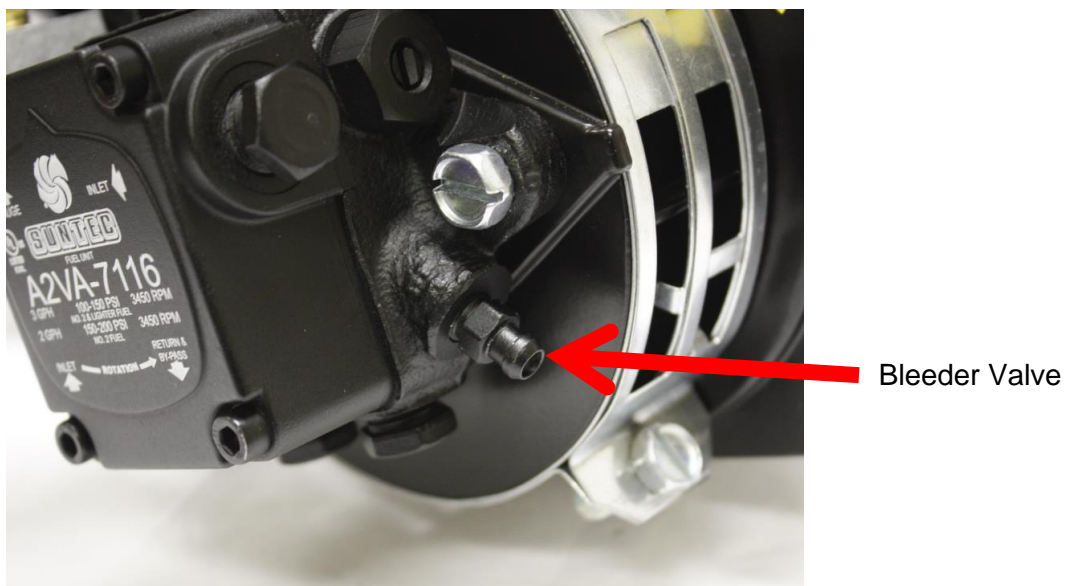


Air Band Adjustment Screw

**Figure 21– Air Band Adjustment Screw Location**

Open the ignition device mounting plate and turn on the electrical breaker.

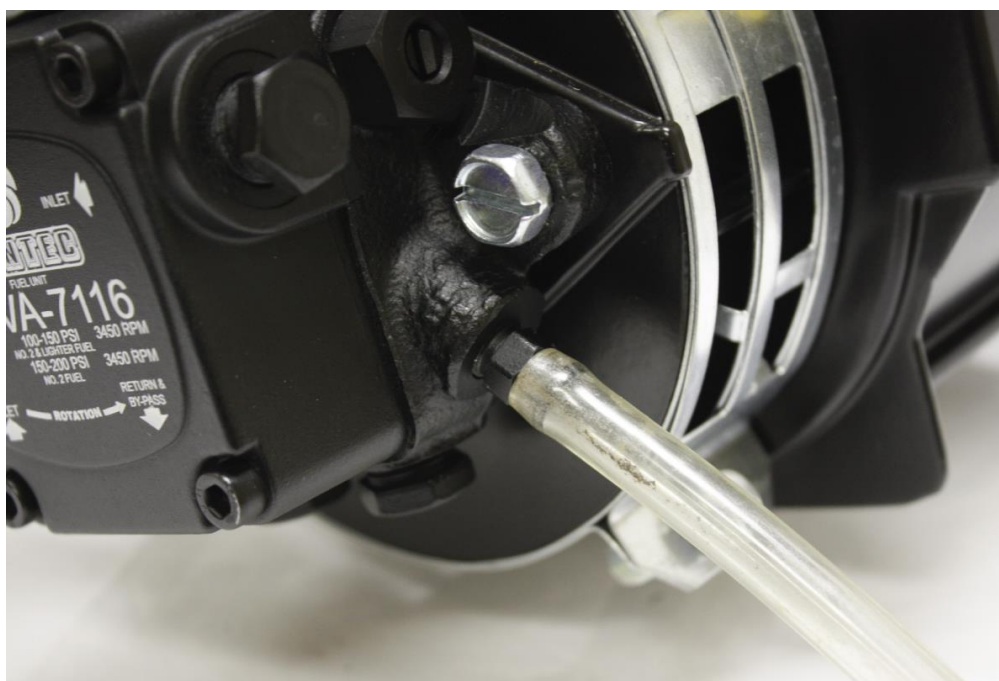
Next, bleed the pump by following steps 1-3 before starting the burner. See Figure 22 for the location of the bleeder valve on the pump.



**Figure 22– Fuel Pump Bleeder Valve Location**

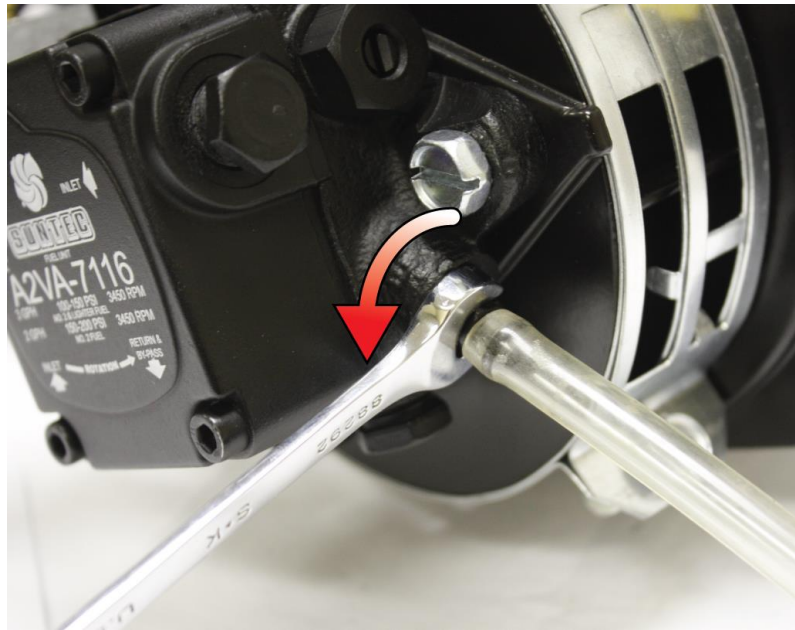
Note: If the pump is set up in two pipe operation with the by-pass plug installed, bleeding the pump is not necessary.

1. Slide a 1/8" Vinyl hose on the bleeder valve as shown in Figure 23 and route the hose into a small container



**Figure 23– Bleeder hose location**

2. With the burner running, use a 3/8 inch wrench to open the bleeder valve about one-half turn (Figure 24). Allow oil to drain into the container until a steady, clear bubble free oil stream is noticed. Close the bleeder plug.



**Figure 24– Bleeder valve adjustment**

Note: If safety lockout occurs during burner operation, reset after one or two minutes.

3. Close the ignition device mounting plate, and tighten the hold down clip screw

## **NOTICE**

Do not run fuel unit dry for more than five minutes or damage to the pump may result.

## **FINAL ADJUSTMENTS**

At this point a final adjustment should be made by the use of a COMBUSTION TEST KIT. After operating for ten minutes to warm up the appliance, a smoke tester should be used to take a smoke reading. Smoke test should read no greater than #1 (Shell Bacharach scale), and less than a #1 smoke is desired. At times, a new heating unit requires more time than this to burn clean due to the oil film on the new heater unit surfaces. Recheck draft and take a CO<sub>2</sub> reading over the fire and in the stack. If a large differential between CO<sub>2</sub> readings is noted, air leakage is the most common cause. CO<sub>2</sub> readings must be taken ahead of draft control, if used. The CO<sub>2</sub> measured in the stack should be at least 10-12% for oil rates 1.00 gal/hr or below, and at least above 10% for oil rates over 1.00 gal/hr Units should be started and stopped several times to assure good operation. Open ignition device mounting plate, unplug solenoid valve lead, and check the oil primary control (if equipped) for normal operation see SEQUENCE OF OPERATION: BURNERS WITH R7284G AND R8184G CONTROLS on pages 17-18. Check operation of limit controls and thermostat. Check for oil leaks.

## **NOTICE**

All new installations should be re-inspected after one or two weeks of normal operation.

## **SETTING COMBUSTION EFFICIENCY**

1. Fire burner, adjust interlocking air bands until smoke from the exhaust changes from black to clear and see through.
2. Record CO<sub>2</sub> and smoke levels. If CO<sub>2</sub> is low, close the air band by a 1/8 inch using a ruler or scale, and repeat CO<sub>2</sub> and smoke test. Continue this adjustment until desired CO<sub>2</sub> and smoke levels are obtained. Record stack temperature.
3. Check lighting with cold and hot chamber.
4. Lock all adjustment screws.



## FINAL CHECKS

Be sure all screws are locked and the controls on heating unit are adjusted in accordance with the heater and control manufacturer's instruction sheets.

Note: O<sub>2</sub> % should be over 3 %, and for CO emissions the lower the better but, typical applications for pressure washers should be under 250 ppm, and under 125 ppm for boilers.

## MAINTENANCE



Before beginning any maintenance work on the burner, be sure that all oil valves from the tank are closed and electrical power to the burner is disconnected.

**The following routine maintenance operations should be performed on the burner once a year:**

- **Filter/strainer:** The oil filter cartridge should be replaced once a year so the fuel oil will not become contaminated and plug up fuel pump and nozzle of oil burner.
- **Nozzle:** The nozzle should be changed at least once a year before the start of the heating season. Replace with proper nozzle.
- **Electrode Settings:** This is very important for reliable ignition of the oil; check these once a year in accordance with the instructions provided in this manual. Replace electrodes if worn excessively or if electrode insulator is oil soaked or cracked.
- **Fan and Blower Housing:** This must be kept clean, free of dirt and lint; open transformer to check fan blades from above. Be sure the electric power is off on burner when the transformer is opened up for this inspection

**Components:** If replacement of a burner component becomes necessary, always use parts recommended by the manufacturer. Specify part numbers and description when ordering. (In all communications, state burner model, serial numbers, and appliance manufacturers and appliance model designation).

# REFERENCE INFORMATION

## Table 3- Efficiency Chart for No. 2 Fuel Oil

		Net Stack Temperature (°F)												
		300°	350°	400°	450°	500°	550°	600°	650°	700°	750°	800°	850°	900°
CO2 % Measured from Flue Exhaust	15	87.5	86.5	85.3	84.3	83.3	82.0	81.0	79.8	78.8	77.5	76.3	75.5	74.3
	14.5	87.5	86.3	85.0	84.0	83.0	81.8	80.8	79.3	78.5	77.3	76.0	75.0	73.8
	14	87.5	86.0	84.8	82.8	82.8	81.5	80.3	79.0	78.0	76.8	75.5	74.5	73.0
	13.5	87.0	85.8	84.5	82.5	83.5	81.3	80.0	78.8	77.5	76.3	75.3	74.0	72.3
	13	86.8	85.5	84.3	83.3	82.0	80.8	79.5	78.3	77.0	75.8	74.5	73.5	71.8
	12.5	86.5	85.3	84.0	83.3	81.5	80.3	79.0	77.8	76.5	75.3	73.8	72.8	71.0
	12	86.3	85.0	83.8	82.5	81.5	79.8	78.5	77.3	75.8	74.5	73.0	71.5	70.3
	11.5	86.0	84.8	83.5	82.0	80.8	79.3	78.0	76.3	75.3	73.8	72.3	70.8	69.5
	11	85.8	84.5	83.0	81.5	80.3	78.8	77.3	75.8	74.5	73.0	71.5	70.0	68.5
	10.5	85.5	84.0	82.5	81.0	79.5	78.0	76.5	75.0	73.8	72.0	70.5	69.0	67.5
	10	85.0	83.5	82.0	80.5	78.8	77.3	75.8	74.3	72.8	71.0	69.5	68.0	66.3
	9.5	84.5	83.0	81.5	79.8	78.0	76.5	75.0	73.3	71.8	70.0	68.3	66.8	65.0
	9	84.0	82.3	80.8	79.0	77.3	75.8	74.0	72.3	70.8	68.8	67.0	65.3	63.5
	8.5	83.5	81.8	80.0	78.3	76.5	74.8	73.0	71.3	69.3	67.5	65.5	63.8	62.0
	8	83.0	81.0	79.3	77.5	75.5	73.8	71.8	70.0	68.0	66.0	64.0	62.0	60.0
	7.5	82.3	80.3	78.5	76.5	74.5	72.5	70.5	68.5	66.5	64.3	62.3	60.0	58.0
	7	81.5	79.5	77.3	75.3	73.3	71.0	69.0	67.0	64.8	62.5	60.3	57.8	55.5
	6.5	80.8	78.5	76.3	74.0	71.8	69.5	67.3	65.0	62.8	60.3	57.8	55.5	53.0
	6	79.8	77.2	75.0	72.5	70.0	67.8	65.3	62.8	60.3	57.5	55.5	52.5	50.0
	5.5	78.5	76.0	73.5	71.0	68.0	65.5	63.0	60.3	57.5	54.5	51.8	49.0	46.5
5	77.3	74.5	71.8	69.0	65.8	63.0	60.0	57.0	54.0	51.0	48.0	45.5	42.5	
4.5	75.5	72.5	69.0	66.3	63.0	60.0	56.8	53.5	50.3	47.0	43.5	40.3	36.8	
4	73.3	69.8	66.3	62.8	59.3	55.8	52.0	48.5	45.0	41.3	37.5	33.8	30.0	

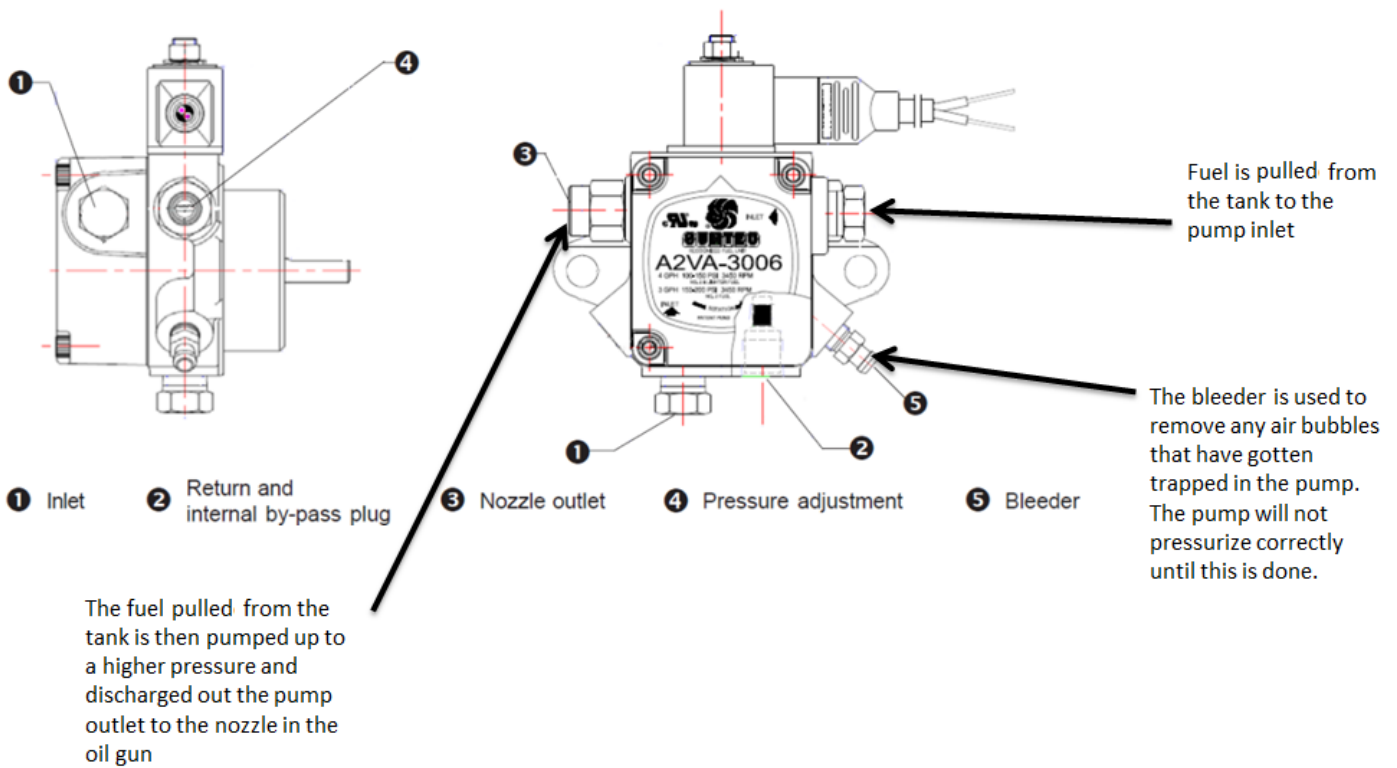
**Table 4– Max Suggested Firing rate for a Given Combustion Chamber Size**

	Firing Rate (gal/hr)	Square Chamber	Diameter Round Chamber	Rectangular Chamber	Rect. Chamber Height	Nozzle Distance to Floor
<b>EHA &amp; EHASR Only</b>	0.75	*	10"	8" x 9"	9"	4"
	1.00	*	11"	10" x 10"	10"	4 1/2"
	1.25	*	12"	11" x 11"	11"	5"
	1.35	*	12"	11" x 11"	11"	5"
	1.50	*	13"	11" x 12"	12"	5"
	1.65	*	14"	12" x 13"	13"	5"
	1.75	*	14"	12" x 13"	13"	5"
	2.00	*	15"	13" x 14"	13 1/2"	5 1/2"
	2.50	*	17"	14" x 16"	14"	5 1/2"
<b>EH Only</b>	3.00	15 1/2" x 15 1/2"	17 1/2"	13" x 18 1/2"	14"	7"
	3.50	17 3/4" x 17 3/4"	20"	15" x 23"	15"	7 1/2"
	4.00	19" x 19"	23 1/2"	16" x 22 1/2"	16"	8"
	4.50	20" x 20"	*	17" x 23 1/2"	17"	8 1/2"
	5.00	23 1/4" x 23 1/4"	*	18" x 25"	18"	9"
	6.00	24 x 1/2" x 24 1/2"	*	23" x 28 1/2"	20"	10"

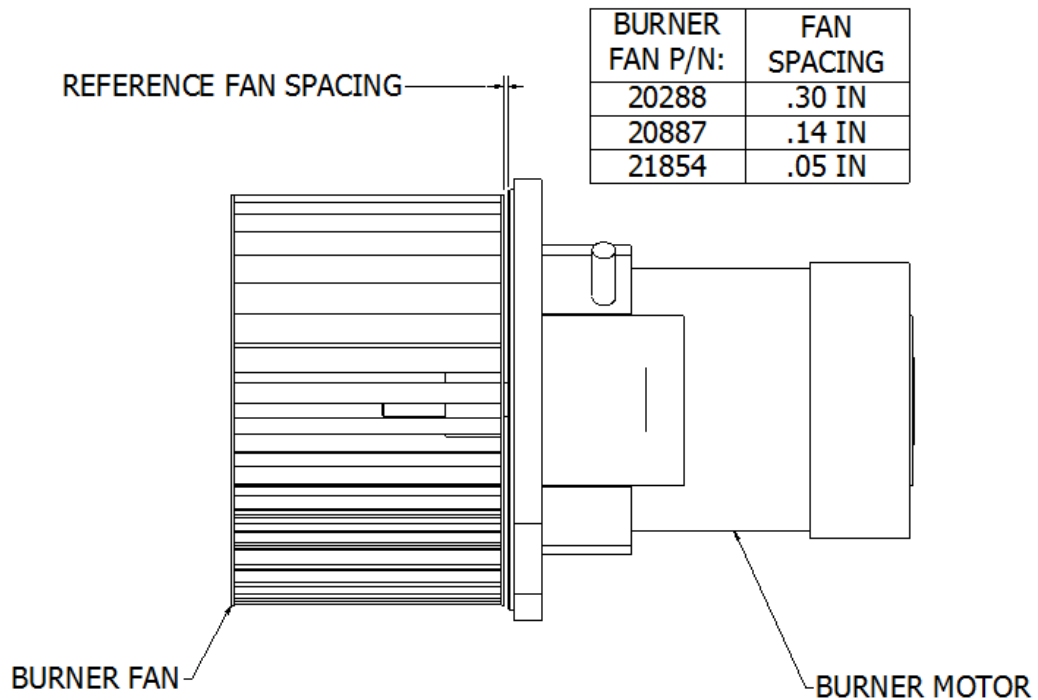
\*- Chamber size not recommended with given firing rate

## REFERENCE FIGURES

### OIL PUMP FEATURE IDENTIFICATION



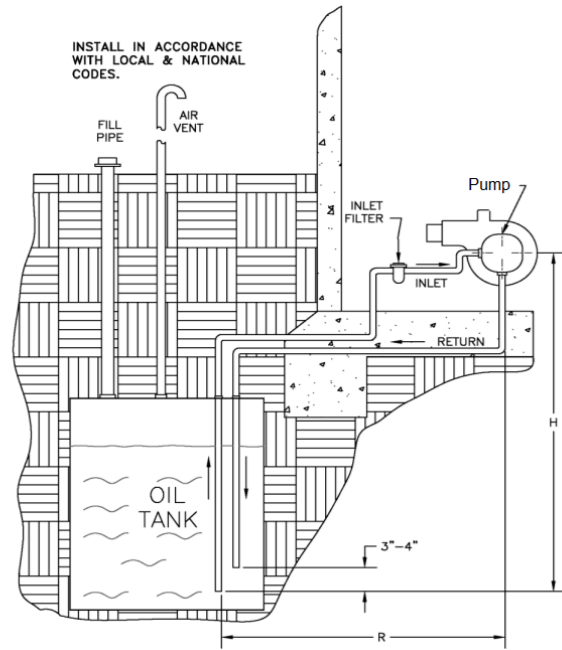
**Figure 25- Pump Feature Identification**



**Figure 26- Blower Wheel Spacing**

## OIL PIPE SIZING INFORMATION

L= Max total line length (ft.), H+R  
 H= Vertical distance in feet from bottom of tank to centerline of pump, or lift (ft.)  
 R= Horizontal distance in feet from tank to centerline of burner pump (ft.)  
 Q=firing rate capacity of fuel pump (gal/hr)



**Figure 27– Fuel line sizing diagram for fuel tank below burner, burner setup in two-pipe operation**

**Table 5: Max Allowable Fuel Line Lengths for two pipe operation**

Inlet Tubing Size	Lift H (ft.)	Model A Single Stage		Model B Two-Stage	
		3450 RPM		3450 RPM	
		3 gal/hr	7 gal/hr	3 gal/hr	7 gal/hr
3/8" O.D. Copper Tubing	0	84	71	93	80
	2	73	62	85	73
	4	63	53	77	66
	6	52	44	69	59
	8	42	35	60	52
	10	31	27	52	45
	12	21	18	44	38
	14	-	-	36	31
	16	-	-	27	24
18	-	-	-	-	
1/2" O.D. Copper Tubing	0	100	100	100	100
	2	100	100	100	100
	4	100	100	100	100
	6	100	100	100	100
	8	100	100	100	100
	10	100	100	100	100
	12	83	70	100	100
	14	41	35	100	100
	16	-	-	100	100
18	-	-	76	65	

NOTE: Max. total line length L=H + R, values were calculated based off a fuel viscosity of 57 SSU. Elbows, valves & filters will further reduce total line length. It is recommended to avoid 3/8" lines where feasible.

## One Pipe Operation

NOTE: For one-pipe operation (no return line) use the following line length equations

3/8" line:  $L=(6-.75H)/.0086Q$

1/2" line:  $L=(6-.75H)/.00238Q$

NOTE: If tank is above the pump, change the "-" to a "+"

### Sample Calculation for one pipe operation

If the fuel tank is installed below the ground and it is found that the distance from the bottom of the tank to the centerline of fuel pump is  $H=7$  ft,  $\frac{1}{2}$  inch copper tubing is being installed, and the oil pump max flow rate is rated at 3 gal/hr according to the label, ( $Q=3$  gal/hr), the maximum total line length ( $L$ ) would be

$$L=(6-.75*(7))/0.00238*(3)$$

$$L \approx 105 \text{ ft.}$$

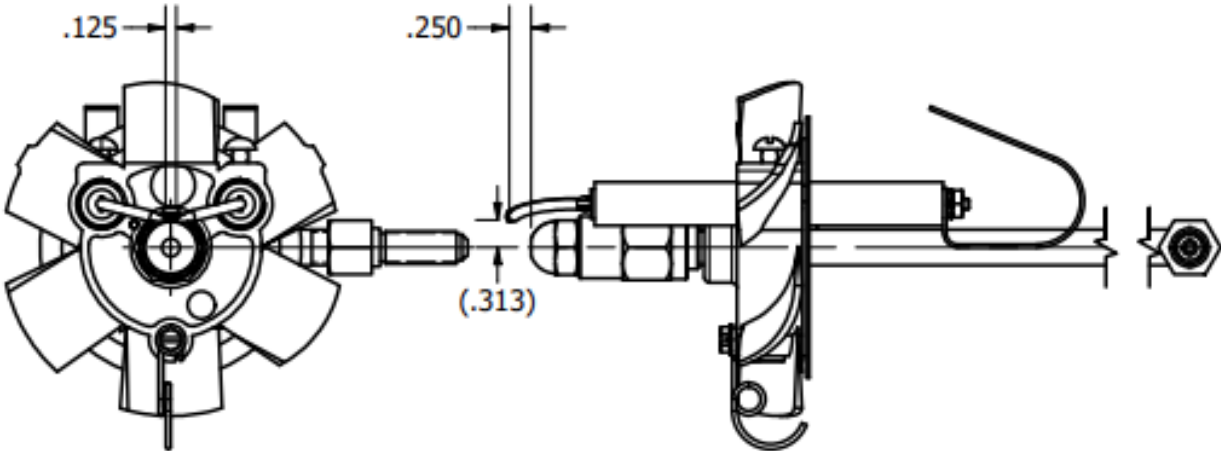
Now to calculate the maximum horizontal distance from the burner pump to the tank ( $R$ )

$$R = L - H,$$

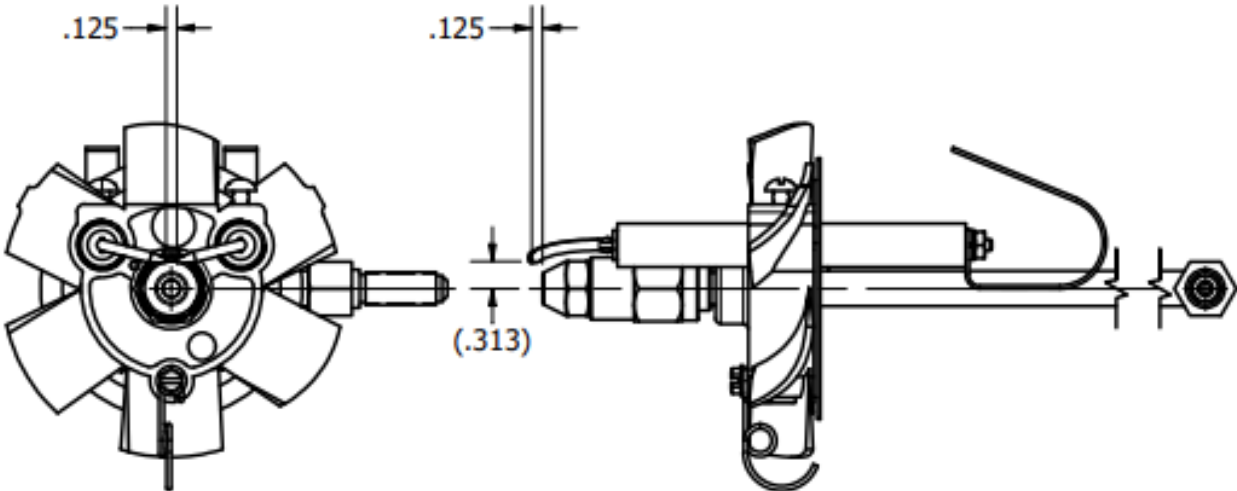
$$R = 105 - 7; \quad R = 98 \text{ ft.}$$

Note: If  $(6-.75H) \leq 0$  or a negative number, based off  $H \geq 8$  it means that the pump will not be able to pull fuel from the tank for that given lift ( $H$ ), either run a return line or use a two-stage pump to overcome this issue.

# ELECTRODE SETTINGS



FOR MONARCH (DOME) NOZZLES



FOR DELAVAN (CONE) NOZZLES

## WARRANTY



# LIMITED WARRANTIES FOR OIL AND GAS BURNERS, MADE BY WAYNE AND USED IN RESIDENTIAL INSTALLATIONS

**WAYNE COMBUSTION SYSTEMS ("WAYNE")** warrants to those who purchase its **Oil Burner Models** for resale or for incorporation into a product of resale, that its burner is free from defects in material and workmanship under normal use and service for thirty-six (36) months from the date of manufacture. **ALL GAS BURNERS** manufactured by "WAYNE" will be similarly warranted for eighteen(18) months from date of manufacture except where original manufacture offers a

greater warranty. (Reference #6 below) THESE LIMITED WARRANTIES DO NOT APPLY UNLESS THE BURNER

COVERED BY IT IS PROPERLY INSTALLED BY A **QUALIFIED, COMPETENT TECHNICIAN**, WHO IS LICENSED WHERE STATE AND/OR LOCAL CODES PREVAIL, AND **WHO IS EXPERIENCED IN MAKING SUCH INSTALLATIONS**, in accordance with NFPA #31 of the national fire protection association and in accordance with all local, state and national codes.

Any **IN-WARRANTY** burner component which is defective in material or workmanship will be either repaired or replaced as follows:

1. Fuel pumps, motors, transformers, gas valves, and controls should be returned to an authorized service station or distributor of WAYNE for determination of applicability of this LIMITED WARRANTY as to either repair or replacement, where said service station or distributor is reasonably available in the customer's locality. The manufacturers of burner components regularly publish and distribute listings showing the locations of their network of service stations. Where such local service is NOT available for the burner components described above or other burner parts are involved, these items should be returned, freight prepaid, to WAYNE Service Department, 801 Glasgow Ave, Fort Wayne, Indiana 46803.
2. Burners and/or component(s) determined to be covered under this LIMITED WARRANTY by WAYNE shall be repaired or replaced at WAYNE's sole option.
3. WAYNE is not responsible for any labor cost for the removal and replacement of said burner or burner components and equipment associated therewith.

4. A burner so repaired will then carry the LIMITED WARRANTY equal to the unexpired portion of the original burner LIMITED WARRANTY.
5. If inspection by WAYNE does **NOT** disclose any defect covered by this LIMITED WARRANTY, the burner or burner component(s) will be either repaired or replaced at the expense of the customer and WAYNE'S regular charges will apply.
6. If the original manufacturer of a burner component offers a warranty greater than either of our LIMITED WARRANTIES described above, then this portion will be added to our LIMITED WARRANTY.

This LIMITED WARRANTY does **NOT** cover products which have been damaged as the result of accident, abuse, misuse, neglect, improper installations, improper maintenance or failure to operate in accordance with WAYNE's written instructions.

These LIMITED WARRANTIES do not extend to anyone except the first purchaser at retail and only when the burner is in the original installation site.

**IMPLIED WARRANTIES OF MERCHANTABILITY AND FITNESS FOR A PARTICULAR PURPOSE SHALL BE LIMITED TO THE DURATION OF THE LIMITED EXPRESS WARRANTIES CONTAINED HEREIN. WAYNE EXPRESSLY DISCLAIMS AND EXCLUDES ANY LIABILITY FOR CONSEQUENTIAL OR INCIDENTAL DAMAGES OF ANY NATURE FOR BREACH OF ANY EXPRESS OR IMPLIED WARRANTY.**

Some states do not allow limitation on how long an implied warranty lasts, so the above limitation may not apply to you. Also, some states do not allow the exclusion or limitation of incidental or consequential damages, so the above limitation or exclusion may not apply to you. WAYNE neither assumes or authorizes any person to assume for WAYNE any other liability or obligation in connection with the sale of these products. This warranty gives you specific legal rights, and you may also have other rights which vary from state to state.



