

OIL BURNERS

EH & EHASR



WAYNE
Combustion Systems™

a Scott Fetzer company

12Vdc EH FEATURES

Wayne's EH and EHASR burners provide a high combustion efficiency that saves fuel, and assures positive flame stability that results in a clean and uniform high temperature flame. The nozzle adaptor bleeds air from line, prevents afterdrip, and eliminates smoke, soot, and carbon formation. Furthermore, the 20,000 V. constant duty ignitor creates positive make or break contact with electrodes and features a swing-away design which offers easy access to the gun assembly.

BURNER HIGHLIGHTS

-  Controlled Flame Pattern
-  Quiet Stops and Starts
-  High Static Pressure Overcomes Adverse Draft Conditions
-  Solid State Ignitors
-  Rugged DC Motors
-  Combo Pumps
-  Easily Adjustable For Peak Performance

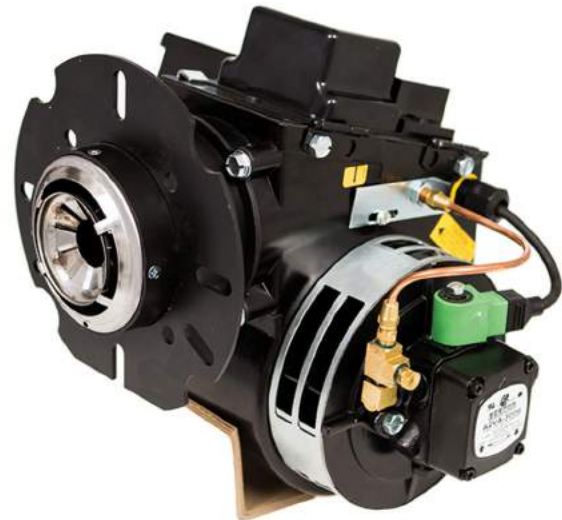

www.waynecombustion.com

Phone: 800.443.4625 | Email: sales@waynecombustion.com

SPECIFICATIONS

OIL BURNERS

EH & EHASR

EH

Capacity	3.00 - 6.00 gal/hr*, No. 1 or No. 2 Fuel Oil.
Fuel Pump	Standard 3450 rpm Fuel Pump. Single or Two Stage.
Controls	Standard - 15 Second Control with CAD Cell Installed.
Ignitor	20,000 V Constant Duty Ignitor.
Motor	13.5 Vdc; Two Sizes Available.
Fan Housing	One Piece, Die Cast Aluminum Which Aligns All Moving Parts.
Mounting	Adjustable or Fixed Mounting Flange.
Nozzle Adapter	No Drip Brass Adapter Ensures Sharp Oil Cutoff When Fuel Pump Shuts Off.
Air Adjustment	Dual Air Adjusting Bands Interlock For Positive Air Adjustment.
Air Tube	Heavy Duty 13 Gauge Seamless Steel Tube Material.
Air Cone	Cast Iron, Adjustable For Firing Rate Ranges.
Shipping Weight	Approximately 42 lbs.

***50 Hz Burners Available**
Maximum Firing Rate Reduced to 5.00 GPH at 50 Hz Operation.

EHASR

Capacity	0.75 - 3.00 gal/hr, No. 1 or No. 2 Fuel Oil or Kerosene.
Fuel Pump	Standard 3450 rpm Fuel Pump.
Controls	Optional Control and CAD Cell.
Ignitor	20,000 V Constant Duty Ignitor.
Motor	13.5 Vdc, Ball Bearing. 3950 rpm, 18 A.
Fan Housing	One Piece, Die Cast Aluminum Which Aligns All Moving Parts.
Mounting	Adjustable or Fixed Mounting Flange.
Nozzle Adapter	No Drip Brass Adapter Ensures Sharp Oil Cutoff When Fuel Pump Shuts Off.
Air Adjustment	Dual Air Adjusting Bands Interlock For Positive Air Adjustment.
Air Tube	Heavy Duty 13 Gauge Seamless Steel Tube Material Available in 3 5/8" - 23" Lengths.
Flame Retention Head	High Temperature Stainless Steel For Longer Life.
Shipping Weight	Approximately 38 lbs.

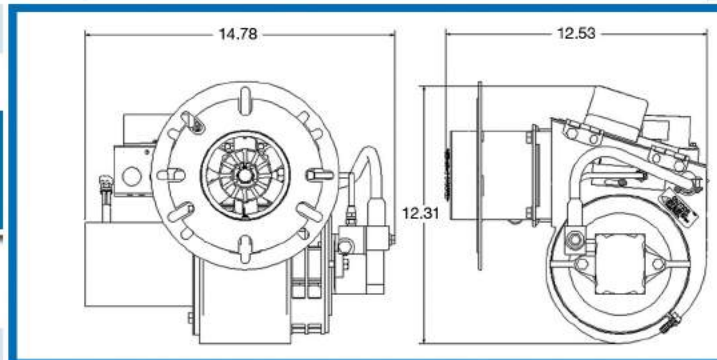

PLEASE CONTACT US FOR FURTHER INFORMATION :

Phone: 800.443.4625 | Email: sales@waynecombustion.com
www.waynecombustion.com